

Amana[®]

Microwave Convection Oven Owner's Manual & Cooking Guide

RMC810*

* Additional alphanumeric characters representing other models in the series may follow each model number.

Keep these instructions for future reference. If the oven changes ownership, be sure this manual accompanies oven.

Contents

Model Identification	2
Microwave Power	2
Asure™ Extended Service Plan	2
IMPORTANT SAFETY INSTRUCTIONS	
Warning	3
Caution	4
Precautions to Avoid Possible Exposure to Excessive Microwave Energy	5
Grounding Instructions	6
Installation	6
Power Supply Cord	6
Radio Interference	6
Unpacking Oven	6
Oven Placement	6
Built-In Capability	6
Oven Features	7
Cooking Methods	
Microwave Cooking	7
Convection Cooking	7
Combination Cooking	7
Utensils	
Microwave Utensil Check Test	8
Convection rack	8
Control Panel	9
Operation	
Clock	10
Micro Time Entry Cooking	10
Preheat for Convection Cooking	10
Convection Cooking	11
Combination Cooking	11
2-Stage Cooking Program	12
Auto Weight Combination Cooking	12
Auto Accu-Thaw	13
Cook Pad Cooking	14
Popcorn Cooking	14
Plus Time Pad Cooking	15
Hold Warm	15
Child Lock	15
Pausing Operation or Canceling Program	15
Care and Cleaning	
Interior, Exterior and Door	16
Control Panel	16
Air Vents	16
Oven Light	16
Before Calling for Service	16

Guides	18
Recipes	
Convenience Food Cooking	25
Sandwiches	25
Starters and Snacks	26
Chicken	27
Fish	29
Beef	30
Pork	31
Vegetables and Side Orders	32
Desserts	34
Quick Reference Instructions	37

Model Identification

Complete the enclosed registration card and promptly return. If registration card is missing, call Consumer Affairs department at 1-800-843-0304. If outside U.S.A., call 1-319-622-5511.

Product information is located on oven serial plate. Record the following information:

Model Number: _____

Manufacturing Number: _____

Serial or S/N Number: _____

Date of purchase: _____

Supplier's name and address: _____

Keep a copy of sales receipt for future reference or in case warranty service is required. For questions call Consumer Affairs Department at 1-800-843-0304 inside U.S.A. 319-622-5511 outside U.S.A. To locate an authorized servicer, call 1-800-628-5782. Warranty service must be performed by an authorized servicer. Amana also recommends contacting an authorized servicer if service is required after warranty expires.

Microwave Power

Models RMC810E and RMC810W deliver 850 watts of microwave power to the oven cavity.

Asure™ Extended Service Plan

Amana offers long-term service protection for this new range. Asure™ Extended Service Plan is specially designed to supplement Amana's strong warranty. Asure™ provides budgetable protection for up to 3 additional years. This plan covers parts, labor, and travel charges. Call 1-800-528-2682 for information.

IMPORTANT SAFETY INSTRUCTIONS

 **Recognize this symbol as a SAFETY message**

WARNING

When using electrical appliances, follow basic safety precautions to reduce the risk of burns, electrical shock, fire, personal injury, or exposure to excessive microwave energy:

1. READ all instructions before using the appliance.
2. READ AND FOLLOW the specific "PRECAUTIONS TO AVOID POSSIBLE EXPOSURE TO EXCESSIVE MICROWAVE ENERGY" found on page 5.
3. This appliance **MUST BE GROUNDED**. Connect only to properly grounded outlet. See "GROUNDING INSTRUCTIONS" on page 6.
4. Install or locate this appliance **ONLY** in accordance with the provided installation instructions.
5. Some products such as whole eggs and sealed containers, for example, closed glass jars may explode and **SHOULD NOT** be HEATED in this oven.
6. Use this appliance **ONLY** for its intended use as described in this manual. Do not use corrosive chemicals or vapors in this appliance. This type of oven is specifically designed to heat or cook. It is not designed for industrial or laboratory use.
7. As with any appliance, **CLOSE SUPERVISION** is necessary when used by **CHILDREN**.
8. **DO NOT** operate this appliance if it has a damaged cord or plug, if it is not working properly, or if it has been damaged or dropped.
9. This appliance should be serviced **ONLY** by qualified service personnel. Contact nearest authorized service facility for examination, repair or adjustment.
10. **DO NOT** cover or block any openings on the appliance.
11. **DO NOT** store this appliance outdoors. **DO NOT** use this product near water, for example, near a kitchen sink, in a wet basement, or near a swimming pool, and the like.
12. **DO NOT** immerse cord or plug in water.
13. Keep cord **AWAY** from **HEATED** surfaces.
14. **DO NOT** let cord hang over edge of table or counter.
15. See door cleaning instructions on page 16.
16. **DO NOT** operate any heating or cooking appliance beneath this appliance.
17. **DO NOT** mount unit over or near any portion of a heating or cooking appliance.
18. **DO NOT** mount over a sink.
19. **DO NOT** store anything directly on top of the appliance surface when the appliance is in operation.
20. Oversized foods or oversized utensils should not be inserted in a microwave/convection oven as they may create a fire or risk of electrical shock.
21. **DO NOT** clean with metal scouring pads. Pieces can burn off the pad and touch electrical parts involving risk of electrical shock.
22. **DO NOT** use paper products when appliance is operated in convection or combination mode.
23. **DO NOT** store any materials, other than manufacturer's recommended accessories, in this appliance when not in use.
24. **DO NOT** cover racks or any other part of the oven with metal foil. Covered racks will cause overheating of the oven.

SAVE THESE INSTRUCTIONS

IMPORTANT SAFETY INSTRUCTIONS



CAUTION

To avoid personal injury or property damage observe the following:

1. Always press STOP/RESET before programming oven.
2. Do not deep fat fry in oven. Fat could overheat and be hazardous to handle.
3. Do not cook or reheat eggs in shell or with an unbroken yolk. Pressure may build up and erupt. Pierce yolk with a fork or knife before cooking. Do not reheat previously cooked eggs in the microwave oven unless finely chopped or scrambled.
4. Pierce skin of potatoes, tomatoes, or other foods with a "skin" before cooking in microwave oven. Piercing skin allows steam to escape during cooking.
5. Do not home can in microwave oven. Home canning is generally done with metal lids. Since metal lids reflect heat, product may not be heated uniformly to 212°F or above. Food could deteriorate. USDA extension specialists do not recommend home canning in microwave ovens.
6. Remove excess fat from meats and poultry to prevent splattering.
7. Do not heat baby bottles in microwave oven.
8. Briskly stir or pour liquids before heating to prevent spontaneous boiling or eruption. Do not overheat. If air is not mixed into a liquid, liquid can erupt in oven or after removal from oven.
9. All uncooked foods should be heated to a final internal temperature of at least 165°F. Some foods require higher temperatures. These recommended temperatures kill most food borne, disease causing organisms. Some common visual signs that indicate the cooking temperature has been reached:
 - Food steams throughout, not just around edges.
 - Center bottom of dish is very hot to the touch.
10. If using a microwave popcorn popper, use according to manufacturer's instructions. Do not continue to heat after popping has stopped. Popcorn will scorch or burn. Do not leave oven unattended.
11. Use only popcorn in packages designed and labeled for microwave use. Pop according to package directions, beginning with the minimum amount of time recommended. Use caution when handling hot popcorn bag.
12. Microwave convenience foods are often packaged in specially designed packaging. Special plates, lids, containers, or other unique packaging materials may be used. Susceptor packing material (a thin, metalized plastic film) is frequently used to help brown and make crisp foods such as microwave pizzas, French fries, or fish sticks. Be sure to follow food package instructions carefully. Contact convenience food manufacturer with questions concerning these products. Amana does not endorse any brand of microwave convenience foods, or any type of microwave food packaging.
13. Do not operate microwave oven empty. This could damage the oven.
14. Do not use regular cooking thermometers in oven. Most cooking thermometers contain mercury and may cause "arcing", malfunction, and/or damage to oven.
15. Metal or ceramic accessories which are designed to absorb microwave energy to provide heat should be used with caution. Test device before use (See "Microwave Utensil Check Test" on page 8). Read and follow manufacturer's instructions provided with the accessory. Contact accessory manufacturer with questions concerning these accessories. Amana does not endorse any brand of accessory.
16. Do not use paper products not intended for cooking when oven is operated in convection or combination mode.
17. Pierce or open plastic bags (and other airtight containers) before heating in microwave oven. This allows steam to escape during cooking.
18. Containers may become hot and pot holders may be needed.
19. Closely supervise any use by children. Make sure they can read instructions and reach controls. Never allow them to lean or swing on oven door.

SAVE THESE INSTRUCTIONS

IMPORTANT SAFETY INSTRUCTIONS



CAUTION

To reduce the risk of fire in the oven cavity:

- a. DO NOT overcook food. Carefully attend appliance if paper, plastic, or other combustible materials are placed inside the oven to facilitate cooking.
- b. Remove wire twist-ties from paper or plastic bags before placing bag in oven.
- c. If materials inside the oven should ignite, keep oven door closed, turn oven off, and disconnect the power cord, or shut off power at the fuse or circuit breaker panel. **IF THE DOOR IS OPENED THE FIRE MAY SPREAD!**
- d. DO NOT use the cavity for storage purposes. DO NOT leave paper products, cooking utensils, or food in the cavity when not in use.



CAUTION

To avoid burns use utensils or protective clothing, like pan grips or dry oven mitts. Racks, utensils, and oven surfaces can become hot during or after use.

PRECAUTIONS TO AVOID POSSIBLE EXPOSURE TO EXCESSIVE MICROWAVE ENERGY

- a. DO NOT attempt to operate this oven with the door open since open-door operation can result in harmful exposure to microwave energy. It is important not to defeat or tamper with the safety interlocks.
- b. DO NOT place any object between the oven front face and the door or allow soil or cleaner residue to accumulate on sealing surfaces.
- c. DO NOT operate the oven if it is damaged. It is particularly important that the oven door close properly and that there is no damage to the: (1) door (bent), (2) hinges and latches (broken or loosened), (3) door seals and sealing surfaces.
- d. The oven should NOT be adjusted or repaired by anyone except properly qualified service personnel.

SAVE THESE INSTRUCTIONS

Grounding Instructions

Installation



WARNING

To avoid the risk of electrical shock or death, this oven must be grounded.

To avoid the risk of electrical shock or death, do not alter the plug.

This oven **MUST** be grounded. In the event of an electrical short circuit, grounding reduces the risk of electric shock by providing an escape wire for the electric current. This oven is equipped with a cord having a grounding wire with a grounding plug. The plug must be plugged into an outlet that is properly installed and grounded.

Consult a qualified electrician or servicer if grounding instructions are not completely understood, or if doubt exists as to whether the oven is properly grounded.

Do not use an extension cord. If the oven power cord is too short, have a qualified electrician install a three-slot receptacle. This oven should be plugged into a separate 60 hertz circuit with the electrical rating as shown in the appropriate drawing. Models require a 120 supply voltage. When oven is on a circuit with another appliance, an increase in cooking times may be required and fuses can be blown.

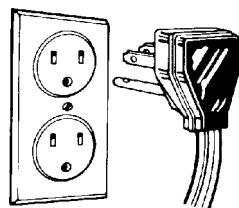

Receptacle / Plug
120V-15AMP

Power Supply Cord

A short power supply cord is provided to reduce the risk of fire and the risk of becoming entangled in or tripping over a longer cord.

Radio Interference

Microwave oven operation may cause interference to radio, TV, or similar equipment. To reduce or eliminate interference:

- Clean door and sealing surfaces of oven. See "Care and Cleaning" section.
- Place the radio, TV, etc. away from oven.
- Use properly installed antenna on radio, TV, etc. to obtain stronger signal reception.

Unpacking Oven

- Inspect microwave oven for damage such as dents in door or dents inside oven cavity.
- Report any dents or breakage to source of purchase immediately. Do not attempt to use oven if damaged.
- Remove all materials from oven interior.
- If oven has been stored in extremely cold area, wait a few hours before plugging in.

Oven Placement

Locate oven on a flat surface. Do not place oven above a gas or electric range. Allow free air flow around oven. Keep all air vents clear. If air vents are covered during operation, oven may overheat. If oven overheats, a thermal safety device automatically turns oven off. Oven will be inoperable until it has cooled.

Built-In Capability

To build-in, use only Amana RMCB2TK27 or RMCW2TK27 trim kits. Trim kits will have a label identifying which microwave oven models may be used.

Oven Features

Oven comes with the following:

- Turntable
- Rotating ring assembly
- Convection rack
- Use and Care Manual

CAUTION

To avoid burns use utensils or protective clothing, like pan grips or dry oven mitts. Racks, utensils, and oven surfaces can become hot during or after use.

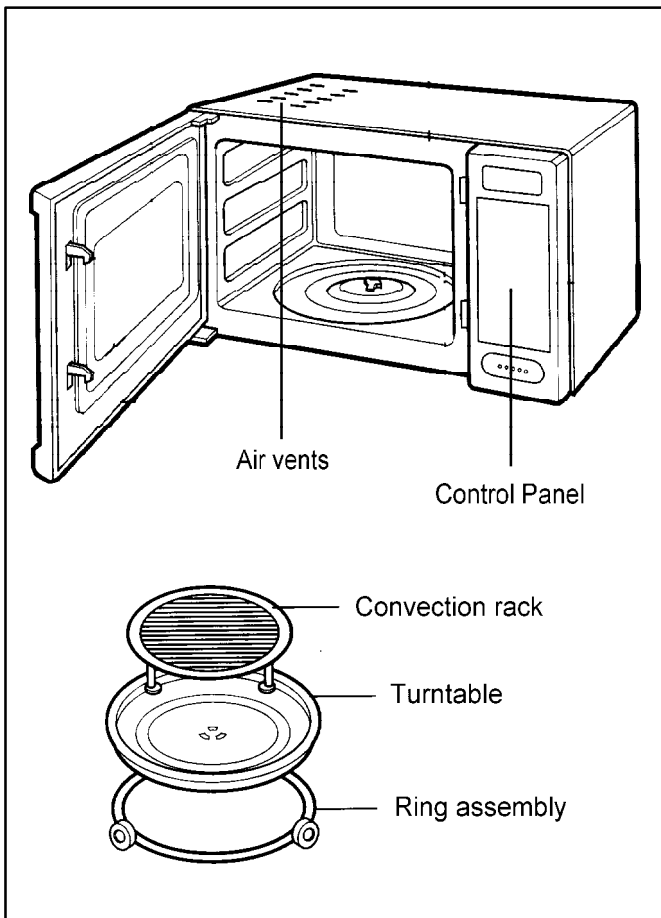

Cooking Methods

Microwave Cooking

Magnetron tube generates microwave energy. Food cooks evenly on rotating turntable.

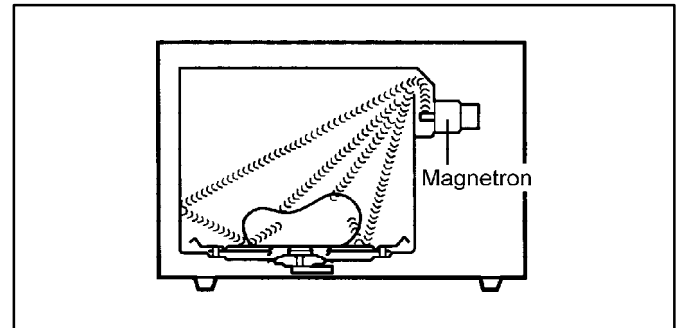

Convection Cooking

Oven cooks with hot air from the convection heater in rear of oven. Food is browned evenly without losing any juices. Fan circulates heated air in oven. Oven temperature is controlled according to food type and weight. Raise oven temperature 25°F above recipe temperatures not in this manual.

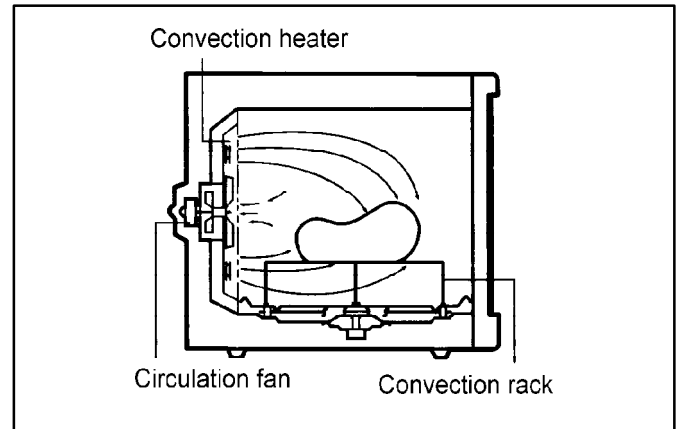

Combination Cooking

Using a combination of microwaves, hot air, and radiant heat, unit cooks according to programmed cycles. Raise oven temperature 25°F above recipe temperatures not in this manual.

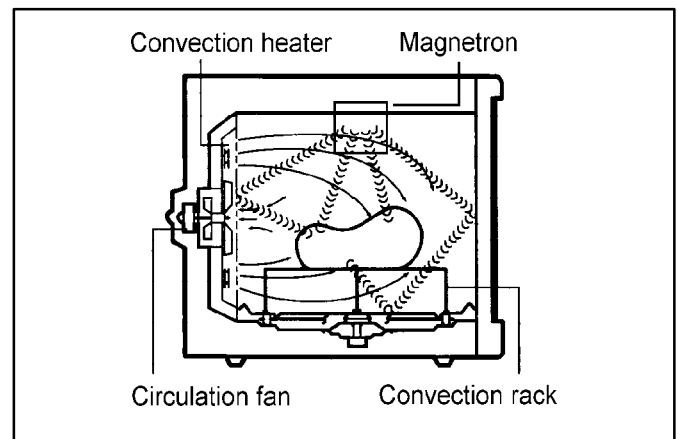

Utensils

Select proper cookware that is appropriate for cooking method for best results.

Microwave

Make sure cookware is safe by using table below and “Microwave Utensil Check Test” section.

Convection

Use metal utensils for baked food or when browning or crusting is desired. Always bake on convection rack.

Combi. High or Combi. Low

Use glass or glass ceramic cookware Do not use cookware with metal trim with combi. high or combi. low.

Microwave Utensil Check Test

Use the following test to check utensils for microwave safeness:

1. In oven cavity, place glass measuring cup of water next to empty dish to be tested.
2. Heat on full power for one minute.
3. Check temperature of tested dish.
 - If dish remains cool and water is hot, dish is microwave safe.
 - If dish is slightly warm, use for short term cooking only.
 - If dish is hot and water is cool, do not use.

Convection rack

Use in microwave, convection or combination cooking. For best cooking results in convection and combination modes use convection rack. Use when cooking popcorn.

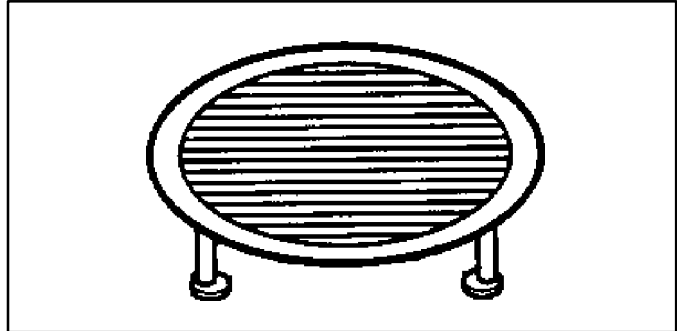

Utensil	Microwave	Convection	Combination
Heat resistant glass	Yes*	Yes	Yes
Ceramic, China	Yes	Yes	Yes
Metal cookware	No	Yes	No
Nonheat resistant glass	No	No	No
Plastics	Yes*	No	No
Plastic wrap, Wax paper	Yes*	No	No
Paper products	Yes*	No	No
Straw, Wicker, Wood	Yes*	No	No

* See “Utensil Check Test” section.

Control Panel

CONV

Convection cooking selector. Convection cooking circulates hot air to cook food.

COMBI. HIGH

Combination high cooking selector. Combination high cooks with 375°F oven temperature and 30% microwave power. When combination cooking, oven alternates between convection and microwave energy.

COMBI. LOW

Combination low cooking selector. Combination low cooks with 350°F oven temperature and 30% microwave power. When combination cooking, oven alternates between convection and microwave energy.

AUTO WEIGHT COMBINATION COOK

Auto weight combination cooking selector. Use Auto Weight Combination Cook to cook food according to food type and weight.

AUTO ACCU-THAW

Auto Accu-thaw selector. Use Auto Accu-thaw to defrost food according to food type and weight.

REHEAT

Auto reheat selector. Reheats plate of food, beverage or baked good.

COOK

Cooks food and beverages using microwave energy. Select potato, frozen or fresh vegetable, or frozen entree category.

POPCORN

Auto popcorn selector.

PLUS TIME

Automatically cooks for 10-30 seconds in 10 second increments.

MICRO TIME ENTRY

Microwave time cooking selector.

COOKMATIC LEVEL

Use to select cooking power of microwave cooking.

HOLD WARM

Select to keep foods warm. Hold food at warm temperature for 60 minutes.

Numbered pads

Use to enter time of day, cooking time, cooking power, cooking temperature, food weight or category.

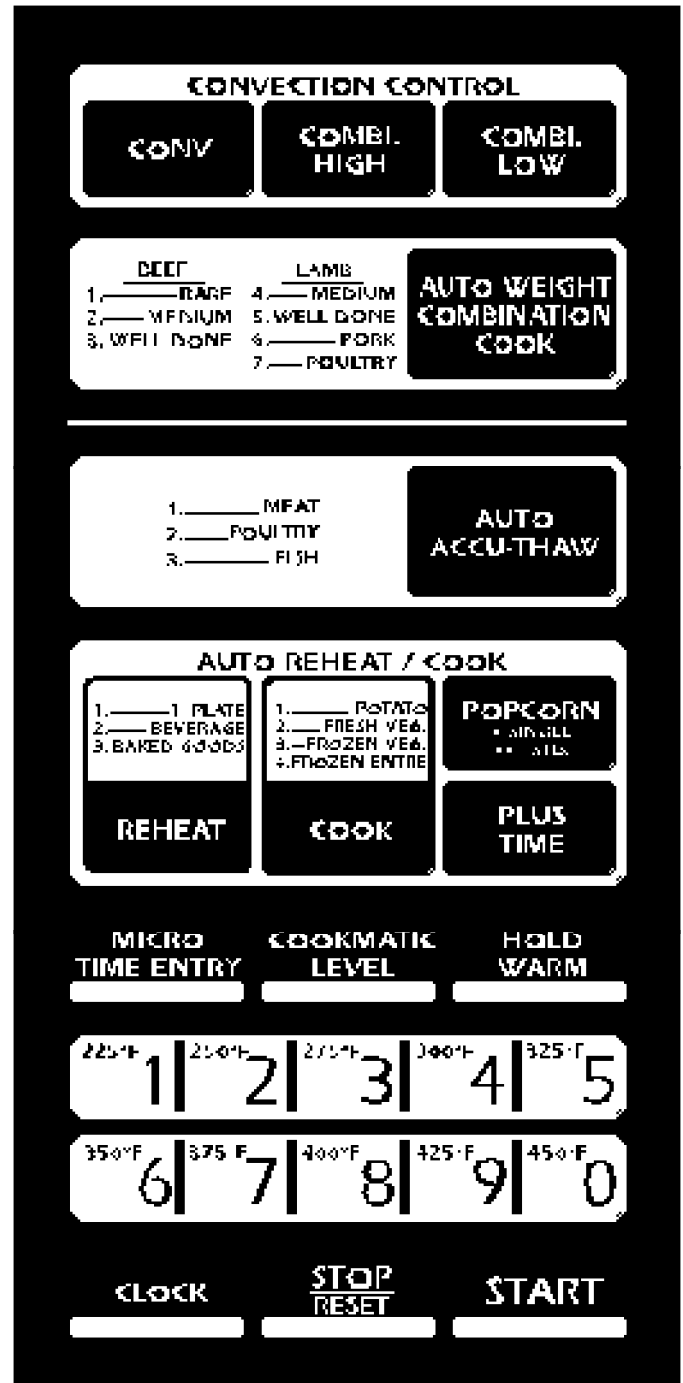

CLOCK

Use to set time of day.

STOP/RESET

Stops oven and clears all entries except time of day.

START

Use to start oven.

Door Open Button (Not shown)

Press to open oven door.

Operation

Clock

Electronic digital clock operates when power is supplied to oven. When oven is plugged in, "0" displays.

1. Press *CLOCK* pad.
 - "ENTER" and "TIME" flash and "12:00" shows in display.
2. Press numbered pad for correct time of day.
 - Selected time of day appears in display. For example, to set the clock for 12:30, press 1,2,3,0 in sequence. Clock does not designate am or pm.
3. Press *CLOCK* pad.

Micro Time Entry Cooking

Use to cook with microwave energy only.

1. Press *MICRO TIME ENTRY* pad.
 - "0" displays and "ENTER", "COOK", and "TIME" flash.
2. Press numbered pads for desired cooking time.
 - To cook at high power, press *START* pad.
 - Selected numbers display. "ENTER" and "START" flash.
3. Press *COOKMATIC LEVEL* pad.
 - "P-HI" displays. "ENTER" and "POWER" flash.
4. Press numbered pads for desired cooking power.
 - Selected power displays. For example, to cook at 70% power, press numbered pad 7. "P-70" displays.
 - "ENTER" and "POWER" flash in display.
5. Press *START* pad.
 - Oven begins cooking.
 - Oven light turns on and "COOK" shows in display.
 - Display alternates showing cooking time counting down and power level.
 - When cooking is complete, signal sounds. "END" displays.
 - Press *STOP/RESET* pad or open oven door to return display to time of day.

Preheat for Convection Cooking

Oven should be preheated when cooking with convection or combination cooking method. Place convection rack in oven before preheating. Preheat temperatures range from 225 to 450°F. Raise oven temperature 25°F above recipe temperatures not in this manual.



To avoid burns use utensils or protective clothing, like pan grips or dry oven mitts. Racks, utensils, and oven surfaces can become hot during or after use.

1. Press *CONVECTION* pad twice.
 - "PRE-H" and "CONV" show in display. "ENTER" and "TEMP" flash in display.
2. Press numbered pad with desired oven temperature.
 - Temperatures are located in upper left corner of numbered pads. For example, if 400°F, press 9. Preheat oven to temperature required for recipe.
 - Selected temperature and "CONV" show in display. "ENTER", "COOK", and "TIME" flash in display.
3. Press *START* pad.
 - Oven turns on. "PRE-H" shows and "CONV" flashes in display.
4. When preheat is complete, "PRE-H" and "CONV" flash and signal sounds.
 - Oven holds preheat temperature for 30 minutes if oven door is not opened or *STOP/RESET* pad pressed. Press *START* pad to continue paused preheat.
 - Press *STOP/RESET* pad and proceed with "Convection Cooking" section.

Convection Cooking

Oven should be preheated when cooking with convection or combination cooking method. Avoid opening oven door frequently. Hot air will escape causing oven temperature to drop and irregular cooking. Raise oven temperature 25°F above recipe temperatures not in this manual.



To avoid burns use utensils or protective clothing, like pan grips or dry oven mitts. Racks, utensils, and oven surfaces can become hot during or after use.

1. Press *CONVECTION* pad.
 - “COOK” and “CONV” show in display. “ENTER” and “TEMP” flash in display .
2. Press number pad with desired oven temperature.
 - Temperatures are located in upper left corner of number pads. For example, if 400°F, press 9.
 - Selected temperature and “CONV” show in display. “ENTER”, “COOK”, and “TIME” flash in display.
3. Press numbers for desired cooking time.
 - Selected time “CONV” show in display. “ENTER” and “START” flash in display.
4. Press *START* pad.
 - Oven begins cooking.
 - “COOK” shows and “CONV” flashes in display.
 - Time and oven temperature alternate in display. Before oven reaches selected temperature, current temperature displays in rising 5°F increments. If oven temperature is lower than 200°F, “LO F” displays until oven temperature reaches 200°F.
 - When cooking is complete, signal sounds. “END” displays.
 - Press *STOP/RESET* pad or open oven door to return display to time of day.

Combination Cooking

Oven should be preheated when cooking with convection or combination cooking method. Cook using Combination High or Combination Low. Combination High cooks at 375°F oven temperature. Combination Low cooks at 350°F oven temperature. Oven cooks with microwave energy and hot, circulating air. When combination cooking, oven alternates between convection and microwave energy.



To avoid burns use utensils or protective clothing, like pan grips or dry oven mitts. Racks, utensils, and oven surfaces can become hot during or after use.

1. Press *COMBINATION HIGH* or *COMBINATION LOW* pad.
 - “HIGH” or “LOW”, and “COMBI” show in display. “ENTER”, “COOK”, and “TIME” flash in display.
2. Press numbered pads for desired cooking time.
 - Selected numbers and “COMBI” show in display. “ENTER” and “START” flash in display.
3. Press *START* pad.
 - Combination cooking begins. “COOK” shows and “COMBI” flashes in display. Selected cooking time counting down and “HIGH” or “LOW” alternately show in display.
 - When cooking is finished, signal sounds and “END” displays.
 - Press *STOP/RESET* pad or open oven door to return display to time of day.

2-Stage Cooking Program

Oven has 2 stage memory. Micro Time Entry, Convection, and Combination High or Low can be set to run 2 cooking programs without stopping.

The programming example:

First program microwave 4 minutes, power level 6.

Second program 15 minutes, 400°F convection.

1. Press *MICRO TIME ENTRY* pad.
2. Press 4, 0, 0 pads in sequence to enter first cooking time.
3. Press *COOKMATIC LEVEL* pad.
4. Press 6 to enter power level 6.
5. Press *CONV* pad.
6. Press 8 numbered pad to enter temperature.
7. Press 1,5,0,0 in sequence to enter time for second cooking time.
8. Press *START* pad.
 - Signal sounds twice between stages. Open door to stir or arrange food between stages. Program will not be lost.
 - When cooking is finished, signal sounds and “END” displays. Press *STOP/RESET* pad or open oven door to return display to time of day.

Auto Weight Combination Cooking

Use to cook food according to food type and weight.

1. Press *AUTO WEIGHT COMBINATION COOK* pad.
 - “AUTO” and “COMBI” show in display. “ENTER” and “CODE” flash in display.
2. Press numbered pad (1-7) to select food type. See table for pads and food types.
 - Selected numbers and “COMBI” show in display. “ENTER” and “WEIGHT” flash in display.
3. Press numbers for desired cooking weight.
 - For example, to set 1.5 pounds, press 1 and 5 in sequence. To enter weight less than 1lb., press 0 pad first.
 - Maximum weight limit is 9.9 pounds for all food types.
 - Selected numbers, “AUTO”, and “COMBI” show in display. “ENTER” and “START” flash in display.
4. Press *START* pad.
 - Auto Weight Combination Cooking begins. “COMBI” flashes in display. “AUTO” and “COOK” show in display. Preprogrammed cooking time counting down.
 - Signal sounds halfway through defrosting time. To stop oven, press *STOP/RESET* pad or open door. Turn food over. Press *START* pad to resume defrosting.
 - When Auto Weight Combination Cooking is complete, oven signal sounds. “END” displays.
 - Press *STOP/RESET* pad or open oven door to return display to time of day.

Numbered pad	Food type
1	Beef, rare
2	Beef, meduim
3	Beef, well done
4	Lamb, meduim
5	Lamb, well done
6	Pork
7	Poultry

Auto Accu-Thaw

Use to defrost food according to food type and weight.

1. Press *AUTO ACCU-THAW* pad.
 - “AUTO” and “DEF” show in display. “CODE” and “ENTER” flash in display.
2. Press numbered pad (1, 2, or 3) to select food type. See table for pads and food types.
 - Selected food type, “AUTO”, and “DEF” show in display. “ENTER” and “WEIGHT” flash in display.
3. Press numbers for desired cooking weight.
 - Selected weight displays. For example to set 1.5 pounds, press 1 and 5 pad in sequence. To enter weight less than 1lb., press 0 pad first.
 - Selected numbers, “AUTO”, and “DEF” show in display. “ENTER” and “START” flash in display.
4. Press *START* pad.
 - Defrost cycle begins, oven light turns on, and preprogrammed defrosting time counts down.” AUTO” and “DEF” show in display.
 - Signal sounds halfway through defrosting time. To stop oven, press *STOP/RESET* pad or open door. Turn food over. Press *START* pad to resume defrosting.
 - When defrosting is complete signal sounds and “END” displays.
 - Press *STOP/RESET* pad or open oven door to return display to time of day.

Numbered pad	Food type	Maximum Weight (lbs.)
1	MEAT Beef Pork Veal Lamb Variety meat	9.9
2	POULTRY Chicken Cornish hen Duck Turkey	9.9
3	FISH Fish Seafood	9.9

Reheat Pad Cooking

Reheats food and beverages using microwave energy. Select category and, 1 or 2 servings. For best results, food should be room temperature, place large or thick pieces of food near the edge of the plate, and stir food after heating.

1. Press *REHEAT* pad.
 - “AUTO” and “REHEAT” show in display. “ENTER” and “CODE” flash in display.
2. Press numbered pad (1, 2, or 3) to select food or beverage type. See table for pads and food types.
 - Pad 1 selects plate of food. Pad 2 selects beverage. Pad 3 selects baked goods.
3. Press numbered pad 1 or 2 to select serving size.
 - Do not hesitate when selecting quantity. Oven starts automatically.
 - Category shows briefly and reheat begins. Oven light turns on, cooking time counts down, and “AUTO” and “REHEAT” show.
 - When reheat cycle is complete signal sounds. “END” displays.
 - Press *STOP/RESET* pad or open oven door to return display to time of day.

Numbered pad	Food type	Serving Size (Ounces)
1	Plate	8
2	Beverage	8
3	Baked Goods	8

Cook Pad Cooking

Cooks food using microwave energy. Select category and, up to 4 servings.

1. Press **COOK** pad.
 - “AUTO” and “COOK” show in display. “ENTER” and “CODE” flash in display.
2. Press numbered pad (1, 2, 3, 4) to select food type.
 - Pad 1 selects Potato. Pad 2 selects Fresh Vegetable. Pad 3 selects Frozen Vegetable. Pad 4 selects Frozen Entree.
3. Press numbered pad 1-4 to select serving size.
 - Do not hesitate when selecting serving size. Oven starts automatically.
 - Category shows briefly and cooking begins. Oven light turns on, cooking time counts down, and “AUTO” and “COOK” show.
 - When cooking cycle is complete signal sounds. “END” displays.
 - Press **STOP/RESET** pad or open oven door to return display to time of day.

Numbered pad	Food type	Serving Size (Ounces)
1	Potato	6
2	Fresh vegetables	4
3	Frozen vegetables	5
4	Frozen entrees	5

Popcorn Cooking

Popcorn cooking cooks popcorn using microwave energy. Cook one bag at a time.



To avoid steam burns when opening bag, wear protective clothing like dry oven mitts and keep face away from bag opening. Escaping steam can burn.

1. Place convection rack on turntable. Place popcorn package on top of convection rack.
2. Press **POPCORN** pad once for 1.8 oz. or twice for 3.5 oz. package.
 - Do not hesitate when selecting serving size. Oven starts automatically.
 - Press once for 1.8 oz. package, twice for 3.5 oz. package.
 - Oven begins cooking. Oven light turns on. “POPCORN” shows briefly then cooking time counts down. “AUTO” and “COOK” show in display.
 - When cooking is complete signal sounds and “END” displays.
 - If additional time is required, use high (100%) power in 20 second increments. Never microwave bag of popcorn more than 5 minutes.

Plus Time Pad Cooking

Automatically cooks or adds 10-30 seconds in 10 second increments.

1. Press *PLUS TIME* pad.
 - Press once for 10 seconds, twice for 20 seconds, 3 times for 30 seconds.
 - Cooking begins.
2. Press *STOP/RESET* pad or open oven door to return display to time of day.

Hold Warm

Hold food at warm temperature for 60 minutes. To automatically have Hold Warm start after a cooking cycle, press Hold Warm and set program according to instructions.

1. Press *HOLD WARM* pad.
 - “HOLD” shows in display. “ENTER” and “START” flash in display.
2. Press *START* pad.
 - Oven begins hold warm cycle. “HOLD” and “COOK” display.
 - When holding time is complete, signal sounds. “END” displays.
 - Press *STOP/RESET* pad or open oven door to return display to time of day.

Child Lock

Oven does not operate. Pads do not function when child lock is on.

1. Press and hold *0* pad until signal sounds.
 - “LOCK” displays.
2. To cancel child lock, press *0* pad until signal sounds and “LOCK” no longer shows.
 - Press *STOP/RESET* pad before making next selection.

Timer

1. Press *MICRO TIME ENTRY*.
2. Press numbered pads for desired time.
 - Time displays.
 - Timer can be set for up to 99 minutes and 99 seconds in one program setting.
3. Press *COOKMATIC LEVEL* pad.
 - “P-HI” displays.
4. Press *0* pad.
 - “P-0” displays.
 - If “0” power is not programmed oven generates microwave energy.
5. Press *START* pad.
 - “COOK” shows in display, selected time counts down, and “P-0” alternately display.
 - When time has elapsed signal sounds. “END” displays.
 - Press *STOP/RESET* pad or open oven door to return display to time of day.

Pausing Operation or Canceling Program

- Press *STOP/RESET* pad or open door to pause operation. Press *START* pad to resume defrosting.
- Press open oven door and press *STOP/RESET* pad or press *STOP/RESET* pad twice to cancel program.

Care and Cleaning

Before Calling for Service

Interior, Exterior and Door

CAUTION

To avoid burns use utensils or protective clothing, like pan grips or dry oven mitts. Racks, utensils, and oven surfaces can become hot during or after use.

If walls, floor, and door of oven become splattered, wipe as soon as possible. Use paper towel, soft sponge or cloth, and mild detergent in warm water. Wring sponge or cloth to remove excess water before wiping unit. Boil a cup of water in microwave oven to loosen soil before cleaning:

- Do not use harsh or abrasive cleaners or cleaners containing ammonia. These could damage finish.
- Never pour water into microwave oven bottom.
- Do not use water pressure type cleaning systems.
- Do not allow water to seep into ventilation openings on oven exterior.

Control Panel

Open oven door to prevent oven from accidentally starting. Wipe with a damp cloth followed immediately by a dry cloth. Press *STOP/RESET* pad after cleaning to clear screen in case any pads were pressed.

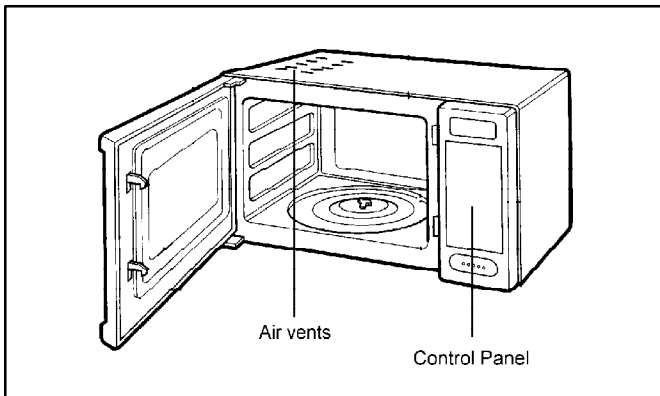

Air Vents

Cooking vapors can buildup along discharge louvers in back of oven on right side. Clean air vent with damp cloth and dry.

Turntable

Wash by hand using mild detergent in warm water or wash in dishwasher.

Oven Light

Oven light must be changed by authorized Amana servicer. See information on contacting a servicer.

Warning

To avoid electrical shock which can cause severe personal injury or death, do not remove outer case at any time. Only authorized servicer should remove outer case.

Readout display does not light up:

- Confirm unit is plugged in on dedicated circuit.
- Confirm unit is on grounded and polarized circuit.
- Check fuse or circuit breaker. Test circuit is operable by plugging another item in wall outlet.

Readout display appears wrong:

- Press *STOP/RESET* pad.

Microwave oven does not operate:

- Confirm door is securely closed.

Food is overcooked:

- Confirm cooking at correct power level.

Food is undercooked:

- Confirm unit is plugged into dedicated circuit.
- Confirm cooking at correct power level.

Keep a copy of sales receipt for future reference or in case warranty service is required. For questions call Consumer Affairs Department at 1-800-843-0304 inside U.S.A. 319-622-5511 outside U.S.A. To locate an authorized servicer, call 1-800-628-5782. Warranty service must be performed by an authorized servicer. Amana also recommends contacting an authorized servicer if service is required after warranty expires.

Cooking Guides and Recipes

Guides

AUTO WEIGHT DEFROST GUIDE - MEAT			
Food	Setting	At Beep	Special Instructions
BEEF			
Ground beef (bulk)	MEAT	Remove thawed portions with fork. Turn over. Return remainder to oven.	Meat of irregular shape and large, fatty cuts of meat should have the narrow or fatty areas shielded with foil at the beginning of a defrost sequence. Do not defrost less than ¼ lb. Freeze in doughnut shape.
Ground beef (patties)	MEAT	Separate and rearrange.	Do not defrost less than two 4-oz. patties. Depress center when freezing.
Hamburger patty	MEAT	Separate and rearrange.	Place on microwavable baking dish.
Pot roast/chuck roast	MEAT	Turn over. Cover warm areas with aluminum foil.	Place on microwavable baking dish.
Rib roast	MEAT	Turn over. Cover warm areas with aluminum foil.	Place on microwavable baking dish.
Rolled rump roast	MEAT	Turn over. Cover warm areas with aluminum foil.	Place on microwavable baking dish.
Round steak	MEAT	Turn over. Cover warm areas with aluminum foil.	Place on microwavable baking dish.
Stew beef	MEAT	Remove thawed portions with fork. Separate remainder. Return remainder to oven.	Place on microwavable baking dish.
Tenderloin steak	MEAT	Turn over. Cover warm areas with aluminum foil.	Place on microwavable baking dish.
LAMB			
Chops (1-inch thick)	MEAT	Separate and rearrange.	Place on microwavable baking dish.
Cubes for stew	MEAT	Remove thawed portions with fork. Separate remainder. Return remainder to oven.	Place on microwavable baking dish.
Rolled roast	MEAT	Turn over. Cover warm areas with aluminum foil.	Place on microwavable baking dish.
PORK			
Bacon	MEAT	Separate and rearrange.	Place on microwavable baking dish.
Chops (½-inch thick)	MEAT	Separate and rearrange.	Place on microwavable baking dish.
Country-style ribs	MEAT	Turn over. Cover warm areas with aluminum foil.	Place on microwavable baking dish.
Hot dogs	MEAT	Separate and rearrange.	Place on microwavable baking dish.
Rolled roast, boneless	MEAT	Turn over. Cover warm areas with aluminum foil.	Place on microwavable baking dish.
Sausage bulk	MEAT	Remove thawed portions with fork. Turn over. Return remainder to oven.	Place on microwavable baking dish.
Sausage links	MEAT	Separate and rearrange.	Place on microwavable baking dish.
Spareribs	MEAT	Turn over. Cover warm areas with aluminum foil.	Place on microwavable baking dish.
VEAL			
Cutlets (1 lb., ½-inch thick)	MEAT	Separate and rearrange.	Place on microwavable baking dish.

AUTO WEIGHT DEFROST GUIDE - POULTRY			
Food	Setting	At Beep	Special Instructions
CHICKEN			
Breasts (boneless)	POULTRY	Separate and turn over. Cover with waxed paper.	No poultry over 5.9 lbs. should be defrosted using AUTO DEFROST, nor should any whole turkeys be defrosted with this setting. Place on microwavable baking dish. Finish defrosting by immersing in cold water.
Cut up	POULTRY	Separate pieces and rearrange. Turn over. Cover warm areas with aluminum foil.	
Whole (under 4 lbs.)	POULTRY	Turn over (breast-side down). Cover warm areas with aluminum foil.	
CORNISH HENS			
Whole	POULTRY	Turn over. Cover warm areas with aluminum foil.	Place on microwavable baking dish. Finish defrosting by immersing in cold water.
TURKEY			
Breast (under 6 lbs.)	POULTRY	Turn over. Cover warm areas with aluminum foil.	Place on microwavable baking dish. Finish defrosting by immersing in cold water.

AUTO WEIGHT DEFROST GUIDE - FISH AND SHELLFISH			
Food	Setting	At Beep	Special Instructions
FISH			
Fillets	FISH	Turn over. Separate fillets when partially thawed.	Place in microwavable baking dish. Carefully separate fillets under cold running water. Place in microwavable baking dish. Finish defrosting under cold running water. Place in microwavable baking dish. Cover head and tail with foil. Do not let foil touch sides of microwave. Finish defrosting by immersing in cold water.
Steaks	FISH	Separate and rearrange.	
Whole	FISH	Turn over.	
SHELLFISH			
Crabmeat	FISH	Break apart. Turn over.	Place in microwavable baking dish.
Lobster tails	FISH	Turn over and rearrange.	Place in microwavable baking dish.
Shrimp	FISH	Break apart and rearrange.	Place in microwavable baking dish.
Scallops	FISH	Break apart and rearrange.	Place in microwavable baking dish.

Cooking Chart

MEAT COOKING CHART			
Meat	Cooking Mode	Cooking Time	Special Instructions
BEEF Corned beef (3 lbs.)	(Cook 1) MICRO POWER HI then (Cook 2) MICRO POWER 3	15 minutes 47 to 53 minutes per pound	Place corned beef in 3-quart microwavable casserole. Pour 1 cup of water and desired seasonings over corned beef. Cook covered. Turn over beef twice during cooking. Shield thinner ends with foil. Cook until fork-tender. Let stand covered 15 minutes. Thinly slice beef diagonally across grain.
Cubes for stew (2 lb. 1-inch cubes)	(Cook 1) MICRO POWER HI then (COOK 2) MICRO POWER 3	10 minutes 36 minutes per pound	Place cubes in 3-quart microwavable casserole. Pour 1 cup of water or broth over cubes. Cook covered. Stir cubes halfway through cooking. Cook until fork-tender. Let stand covered 10 minutes.
Ground beef (1 lb.)	MICRO POWER HI	5 to 6 minutes	Crumble beef and place in microwavable sieve or colander. Place sieve in microwavable bowl to collect drippings. Cover with waxed paper. Stir after 3 minutes to break meat apart. After cooking let stand covered 2 minutes. If meat is still pink, cover and cook 1 more minute.
Hamburgers, fresh or defrosted frozen (4 oz. each) 1 patty 2 patties 4 patties	COMBI HIGH	9 to 10 minutes 9 to 10 minutes 11 to 12 minutes	Arrange patties on microwavable and ovenproof baking dish. Place roast rack or convection rack on turntable. Remove from oven and let stand 1 to 2 minutes.
Pot roast (3-4 lbs.)	(Cook 1) MICRO POWER HI then (Cook 2) MICRO POWER 3	15 minutes 42 to 47 minutes per pound	Pierce roast deeply on both sides in several places. Place roast in large cooking bag; place in microwavable dish. Add desired seasonings and 1 cup of liquid over roast. Close bag loosely with microwavable closure or string. Carefully turn meat over after 45 minutes. Continue cooking until fork-tender. Let stand in bag 10 minutes.
Rib roast, rolled (3-4 lbs.)	COMBI HIGH	11 to 13 minutes per pound, RARE (135°F) 13 to 16 minutes per pound, MEDIUM (155°F)	Place roast fat side down on microwavable and ovenproof baking dish. Add desired seasonings and place on convection rack on turntable. Shield if necessary. Turn over halfway through cook time. Remove from oven and let stand covered with foil 15 minutes. (Temperature may rise about 10°F.)
Rump roast, rolled (3-4 lbs.)	COMBI HIGH	20 to 22 minutes per pound, RARE (135°F) 23 to 25 minutes per pound, MEDIUM (155°F)	Place roast fat side down on microwavable and ovenproof baking dish. Add desired seasonings and place on convection rack on turntable. Shield if necessary. Turn over halfway through cook time. Remove from oven and let stand covered with foil 15 minutes. (Temperature may rise about 10°F.)
Sirloin tip roast (3-4 lbs.)	COMBI HIGH	11 to 13 minutes per pound, RARE (135°F). 13 to 16 minutes per pound, MEDIUM (155°F).	Place roast fat side down on microwavable and ovenproof baking dish. Add desired seasonings and place on convection rack on turntable. Turn over halfway through cook time. Remove from oven and let stand covered with foil 15 minutes. (Temperature may rise about 10°F.)

Lamb Lamb roast, rolled, boneless (3-4 lbs.)	COMBI HIGH	12 to 13 minutes per pound, RARE (135°F) 14 to 15 minutes per pound, MEDIUM (145°F) 16 to 16½ minutes per pound, WELL (155°F)	Place roast fat side down on microwavable and ovenproof baking dish. Brush with marinade and desired seasonings such as rosemary, thyme or marjoram. Place on convection rack on turntable. Turn over halfway through cook time. Remove from oven and let stand covered with foil 15 minutes. (Temperature may rise about 10°F.)
Lamb stew cubes (2 lbs.) 1-inch cubes	(Cook 1) MICRO POWER HI then (COOK 2) MICRO POWER 3	10 minutes 37 minutes per pound	Place cubes in 2-quart microwavable casserole. Add desired seasonings such as rosemary, thyme and marjoram and 1 cup of water. Cook covered. Stir cubes twice during cooking. Cook until fork-tender. Let stand covered 15 minutes.
PORK Bacon slices 2 slices 4 slices 6 slices	MICRO POWER HI	1½ to 2 minutes 3 to 4 minutes 4½ to 5½ minutes	Place bacon slices on microwavable roast rack. Cover with microwavable paper towel. After cooking let stand covered 1 minute.
Canadian bacon 2 slices 4 slices 6 slices	MICRO POWER HI	30 to 45 seconds 1 to 1½ minutes 1 to 2 minutes	Place meat on microwavable roast rack. Cover loosely with waxed paper. After cooking let stand covered 1 minute.
Chops 2 chops (about 12 oz.) 4 chops (1½ lbs.)	COMBI LOW	16 to 19 minutes 30 to 35 minutes	Place chops in microwavable and ovenproof baking dish. Add desired seasonings and place on convection rack on turntable. Cook until no longer pink or until internal temperature reaches 170°F. Turn over chops halfway through cooking. Remove from oven and let stand covered 5 minutes. (Temperature may rise about 10°F.)
Hot dogs 1 2 4	MICRO POWER HI	30 to 45 seconds 45 to 60 seconds 1 to 2 minutes	Pierce hot dogs and place on microwavable baking dish. Cover with waxed paper. If in bun, wrap in microwavable paper towel or paper napkin to absorb moisture. After cooking, let stand 30 seconds to 1 minute.
Ham, boneless fully cooked 2 lbs. 5 lbs.	MICRO POWER 5	10 to 15 minutes per pound	Place ham on microwavable baking dish. Cover with waxed paper. Turn ham over halfway through cooking. Cook until internal temperature reaches 120°F. Let stand covered 10 minutes.
Ham, center slice (1 lb.)	MICRO POWER 5	5 to 6 minutes	Place slice on microwavable baking dish. Cover with plastic wrap; vent. After cooking let stand covered 1 minute.
Loin roast, rolled, boneless (3½-4½ lbs.)	COMBI LOW	15 to 17 minutes per pound	Place roast on microwavable and ovenproof baking dish. Add desired seasonings and place on CONVECTION Rack on turntable. Turn over halfway through cooking time. After cooking remove from oven and let stand 15 minutes. (Temperature may rise about 10°F.) Internal temperature of pork should reach 170°F before serving.

Sausage links, fresh or defrosted frozen	CONVECTION 400°F	12 to 14 minutes	Preheat CONVECTION to 400°F. Pierce links and place on ovenproof baking dish. Turn links over halfway through cooking.
Sausage patties, fresh (2 oz. each) 2 patties 4 patties 6 patties	CONVECTION 400°F	18 to 20 minutes	Place sausage patties on ovenproof baking dish. Turn patties over after 10 minutes of cooking.
Spareribs (2½-3½ lbs.)	MICRO POWER 5 then MICRO POWER 5 (if desired)	27 to 32 minutes per pound (165°F) 10 minutes (if desired)	Place ribs, cut into serving size pieces, bone side down in large cooking bag. Place bag in 3-quart microwavable casserole. Add 1 cup of water to bag. Close bag loosely with microwavable closure or string. Turn ribs over, rearranging carefully, halfway through cooking. Cook until meat is fork-tender. Carefully remove ribs. If desired, place ribs on microwavable roast rack and brush sauce over ribs. Cook covered with waxed paper. Let stand covered 10 minutes. (Temperature may rise about 10°F.) Internal temperature of pork should reach 170°F before serving.

NOTE: Using oven mitts, or hot pads, carefully insert and remove turntable and convection rack together for ease in handling.

POULTRY COOKING CHART			
Poultry	Cooking Mode	Cooking Time	Special Instructions
Chicken			
Breasts, boneless, skinless 1 half breast (4-5 oz.) 1 whole breast (10-12 oz.)	COMBI HIGH COMBI HIGH	6 to 8 minutes 15 to 17 minutes	Wash and dry poultry. Place breasts, thickest portions to outside, on microwavable and ovenproof baking dish. Place on convection rack on turntable. Brush with butter and seasonings if desired. Cook until no longer pink and juices run clear. Remove from oven and let stand covered 3 minutes.
Cut up fryer (2½-3 lbs.)	COMBI HIGH	30 to 35 minutes	Wash and dry poultry. Arrange pieces on microwavable and ovenproof baking dish with skin side down and thickest pieces to the outside. Brush with butter and seasonings if desired. Place on convection rack on turntable. Cook until no longer pink and juices run clear. Turn over halfway through cook time. Remove from oven and let stand covered 5 minutes.
Whole (3-3½ lbs.)	COMBI HIGH	35 to 40 minutes	Wash and dry poultry. Place on microwavable and ovenproof baking dish with breast side down. Brush with butter and seasonings if desired. Place on convection rack on turntable. Cook until no longer pink and juices run clear. Turn over halfway through cook time. Remove from oven and let stand covered with foil 10 minutes. (Temperature may rise about 10°F.) Temperature in thigh should be about 175°F - 185°F when done.

Cornish hens Two whole (1-1½ lbs. each)	COMBI HIGH	35 to 40 minutes	Wash and dry poultry. Tie wings to body of hen and the legs to tail. Place hens breast side up on microwavable and ovenproof baking dish. Brush with butter and seasonings if desired. Place on convection rack on turntable. Remove and discard drippings and shield bone ends of drumsticks with foil halfway through cooking if needed. Cook until no longer pink and juices run clear. Remove from oven and let stand covered with foil 5 minutes. (Temperature may rise about 10°F.) Temperature in breast should be 170°F before serving.
Turkey breast, boneless (2-3 lbs.)	COMBI HIGH	20 to 25 minutes per pound	Place thawed turkey breast on microwavable and ovenproof baking dish. Brush with butter and seasonings if desired. Place on convection rack on turntable. Turn over halfway through cook time. Cook until no longer pink and juices run clear. Remove from oven and let stand covered with foil 10 minutes. (Temperature may rise about 10°F.) Temperature in breast should be 170°F before serving.
Turkey breast, whole, bone-in (4-9 lbs.)	COMBI HIGH	10 to 11 minutes per pound	Wash and dry poultry. Place turkey breast on microwavable and ovenproof baking dish. Brush with butter and seasonings if desired. Place on convection rack on turntable. Turn breast over and remove and discard drippings halfway through cooking. Cook until no longer pink and juices run clear. Remove from oven and let stand covered with foil 10 minutes. (Temperature may rise about 10°F.) Temperature in breast should be 170°F before serving.
Drumsticks (1½-2 lbs.)	COMBI HIGH	25 to 30 minutes	Wash and dry poultry. Place pieces with thickest portion to outside on microwavable and ovenproof baking dish. Brush with butter and seasonings if desired. Place on convection rack on turntable. Cook until no longer pink and juices run clear. Turn over halfway through cook time. Remove from oven and let stand covered with foil 5 minutes.

NOTE: Using oven mitts or hot pads, carefully insert and remove turntable and convection rack together for ease in handling.

FISH AND SHELLFISH COOKING CHART

Fish and Shellfish	Cooking Mode	Cooking Time Minutes per Pound	Special Instructions
Fish fillets	MICRO POWER HI	4 to 5 minutes	Arrange fish in a single layer with thickest portion toward outside edge of 1½-quart microwavable baking dish. Brush with melted butter and season, if desired. Cook covered with plastic wrap; vent. Let stand covered 2 minutes.
Fish steaks	MICRO POWER HI	4 to 5 minutes	Arrange fish in a single layer with thickest portion toward outside edge of 1½-quart microwavable baking dish. Brush with melted butter and season, if desired. Cook covered with plastic wrap; vent. Let stand covered 2 minutes.
Whole fish	MICRO POWER 7	6 to 7 minutes	Arrange fish in a single layer with thickest portion toward outside edge of 1½-quart microwavable baking dish. Brush with melted butter and season, if desired. Cook covered with plastic wrap; vent. Let stand covered 2 minutes.
Scallops, sea	MICRO POWER HI	3 to 4 minutes	Prepare as directed above, except stir halfway through cooking.
Shrimp, shelled	MICRO POWER HI	3 to 4 minutes	Prepare as directed above, except stir halfway through cooking.
Lobster tail	MICRO POWER HI	4 to 5 minutes	Cut hard shell down middle with knife. Grasp tail with both hands and open flat. Place flesh side up in 8x8x2-inch square glass baking dish. Cook covered with waxed paper. Let stand covered 2 minutes.

Recipes

Convenience Food Cooking

Convection cooking is now made easier with the large number of ready-to-bake frozen foods, quick breads and muffins available. Most of these convenience products can be successfully baked in your oven by following a few simple guidelines.

1. For more browning of frozen foods and baked goods use metal pans. Dark metal will provide a browner product than shiny metal since the dark metal surface absorbs more heat.
2. Always bake on the convection rack. The rack allows heated air to circulate around food to promote even cooking and browning.
3. Always preheat oven for recommended temperature listed on package directions.
4. Cook or bake beginning with minimum time listed on package directions. Check food doneness after minimum cooking time, add time if necessary.
5. For baking bars or casseroles, such as lasagna, use a 7x10-inch metal pan or a 1½-quart glass utility dish since 9x13-inch pan will not fit on the turntable. If using a 7x10-inch pan, the bake time may need to be increased by 5 to 10 minutes.
6. Use a 6-cup muffin tin for baking muffins or cupcakes.
7. Raise oven temperature 25°F above recipe temperatures not in this manual.

Sandwiches

SLOPPY JOES

- 1 pound lean ground beef
- 1 cup finely chopped onions
- $\frac{2}{3}$ cup ketchup
- 2 tablespoons pickle relish
- $\frac{1}{2}$ teaspoon salt
- $\frac{1}{4}$ teaspoon black pepper
- 6 hamburger buns, toasted

Put ground beef and onions into a 2-quart microwavable casserole. Cook uncovered at POWER HI for 2 minutes. Break up beef with a fork. Cook uncovered at POWER HI for 2 to 2½ minutes or until pink nearly disappears; drain. Add ketchup, relish, salt, and pepper; mix well. Cook covered POWER HI for 3 to 4 minutes or until thoroughly heated; stir once. Let stand covered 5 minutes. Serve on buns. 6 servings.

BARBECUED PORK SANDWICHES

- 2 pounds blade pork steaks
- 1 can (12 ounces) beer
- 1 small onion, thinly sliced
- 1 clove garlic, quartered
- 1 bay leaf
- $\frac{1}{2}$ cup barbecue sauce
- $\frac{1}{4}$ cup chili sauce
- $\frac{1}{4}$ teaspoon black pepper
- 4 loaves (6 inch) pita bread (with pockets), cut in half crosswise
- shredded lettuce or coleslaw

Put pork into a 3-quart microwavable casserole; add beer, onion, garlic, and bay leaf. Cook covered at POWER HI for 10 minutes; and then at POWER 3 for 50 to 55 minutes or until pork is tender. Let stand covered 10 minutes. Remove pork and onion; discard liquid. Let stand until cool enough to handle. Shred pork; return to casserole. Add reserved onion, barbecue sauce, chili sauce, and pepper; mix well. Cook covered at POWER HI for 3 to 4 minutes or until thoroughly heated. Serve in pita bread; top with shredded lettuce or coleslaw. 4 servings.

BACON-CHEESEBURGERS

- 3 slices bacon
- 1 pound lean ground beef
- 2 teaspoons Worcestershire sauce
- ¼ teaspoon onion powder
- ⅛ teaspoon black pepper
- 4 slices Swiss cheese
- 4 hamburger buns, toasted

Place bacon on a microwavable roast rack. Cover with double thickness of paper towel. Cook at POWER HI for 2 to 3 minutes or until just crisp. Cool; crumble. Combine bacon, ground beef, Worcestershire sauce, onion powder, and pepper in a mixing bowl. Shape mixture into four ½-inch thick patties; arrange on a microwavable and ovenproof baking dish. Place on convection rack and turntable. Cook at COMBI HIGH for 13 to 16 minutes or until well done. Top each patty with a Swiss cheese slice. Cook at COMBI HIGH for 45 to 60 seconds or until cheese is melted. Serve on buns. 4 servings.

OPEN-FACE SUB MELTS

- 1 cup thinly sliced mushrooms
- 4 thin green pepper rings, cut in half
- 2 thin red onion slices, separated into rings
- 2 radishes, thinly sliced
- ¼ cup Italian salad dressing
- 1 loaf (10 inches) French bread
- ¼ cup mayonnaise
- 6 slices tomato
- 4 slices (1-½ ounces each) mozzarella or Swiss cheese
- ½ pound (8 ounces) sliced salami, bologna, turkey, roast beef, or ham
- Alfalfa sprouts

Combine mushrooms, green pepper, onion, and radishes in a small mixing bowl. Pour dressing over vegetables; toss lightly to coat. Set aside to marinate for 15 to 20 minutes. Preheat CONVECTION to 425°F. Slice bread loaf in half lengthwise, then in half crosswise to make four halves. Spread mayonnaise on each bread half; set aside. Drain vegetables; discard marinade. Layer each bread half with marinated vegetables, tomato, meat and cheese. Place bread halves on CONVECTION Rack on turntable. Cook at CONVECTION (450°F) for 8 to 10 minutes or until cheese is melted. Garnish with alfalfa sprouts. 4 servings.

OPEN-FACE TUNA MELTS

- 1 can (6-½ ounces) tuna, drained and flaked
- ¾ cup alfalfa sprouts
- ⅓ cup mayonnaise
- ⅓ cup sliced celery
- ¼ cup thinly sliced green onions
- ½ teaspoon dried dill weed
- ⅛ teaspoon salt
- dash black pepper
- 4 slices whole wheat bread, toasted
- 4 large slices tomato, cut ¼-inch thick
- 4 slices American cheese

Preheat CONVECTION to 450°F. Combine tuna, alfalfa sprouts, mayonnaise, celery, green onions, dill weed, salt, and pepper; mix well. Place ¼ of tuna mixture on each bread slice; spread evenly to edges. Top with tomato slice and then cheese slice. Place bread slices on convection rack on turntable. Cook at CONVECTION (450°F) for 9 to 10 minutes or until cheese is melted. 4 servings.

Starters and Snacks

PIGS IN A BLANKET

- 1 package (8 ounces) refrigerated crescent dinner rolls.
- 1 pound cocktail franks or Vienna sausages
- spicy brown mustard

Preheat CONVECTION to 400°F. Unroll dough onto light floured surface; separate in to four rectangles. Pinch seams to seal perforations. Beginning at shorter side, cut each rectangle into 12 thin strips (each about ½-inch wide) with scissors. Wrap each frank with dough strip. Place 16 wrapped franks at a time in an 8x8x2-inch glass baking pan. Cook at CONVECTION (400°F) for 12 to 14 minutes or until lightly browned and thoroughly heated. Repeat with remaining franks. Serve with spicy brown mustard. 48 appetizers.

GRANOLA

- 2 cups quick oats, uncooked
- ½ cup almonds, coarsely chopped
- ¼ cup roasted sunflower seeds
- ¼ cup toasted wheat germ
- ¼ cup shredded, sweetened coconut
- ½ cup chopped dates
- ½ cup raisins
- ⅓ cup honey
- 1 teaspoon vanilla extract

Combine oats, almonds, sunflower seeds, wheat germ, and coconut in an 8x8x2-inch glass baking dish. Preheat CONVECTION to 425°F. Cook at CONVECTION (450°F) for 10 to 12 minutes; stir every 2 minutes. Add dates, raisins, honey, and vanilla; stir to coat. Reduce CONVECTION to 400°F. Cook at CONVECTION (400°F) for 8 to 10 minutes; stir every 2 minutes. Allow to cool completely; stir occasionally. Store in an air-tight container. 8 servings.

STUFFED MUSHROOM CAPS

- 8 ounces fresh medium mushrooms (about 15 mushrooms)
- 2 tablespoons butter or margarine
- 2 tablespoons sliced green onion
- 1 tablespoon brandy
- ¼ cup herb and garlic cheese spread
- 2 tablespoons dry bread crumbs
- 2 tablespoons finely chopped pecans
- 1 tablespoon chopped fresh parsley

Clean mushrooms by wiping with damp paper towels. Remove stems; set caps aside. Finely chop stems. Put butter and green onion into a 1-quart glass measuring cup. Cook uncovered at POWER HI for 1 to 1½ minutes or until butter is melted. Add chopped mushrooms and brandy; mix well. Cook uncovered at POWER HI for 3 minutes; stir once. Add cheese spread, bread crumbs, pecans, and parsley; mix well. Spoon stuffing mixture into mushroom caps. Place mushroom caps on paper towel-lined microwavable plate. Cook uncovered at POWER HI for 3 to 4 minutes or until mushrooms are tender. About 15 appetizers.

CONFETTI MACARONI AND CHEESE

- White Sauce (see recipe)
- 1 cup elbow macaroni (about 4 ounces), cooked, drained
- 1 cup boiled or baked ham, cut into ½-inch cubes
- 1 cup shredded Cheddar cheese
- ½ cup frozen peas
- ¼ cup grated Parmesan cheese
- 1 tablespoon Dijon-style mustard

Prepare White Sauce as directed in recipe. Combine white sauce, macaroni, ham, Cheddar cheese, peas, Parmesan cheese, and mustard in a 2-quart microwavable casserole; mix thoroughly. Cook uncovered at POWER HI for 4 to 5 minutes or until hot; stir once. Let stand 1 minute. 4 servings.

Chicken

CHICKEN CORDON BLEU

- 4 pieces skinless, boneless chicken breasts (about 4 ounces each)
- 2 ounces Swiss cheese, cut into thin strips
- 2 ounces baked ham, cut into thin strips
- 1 egg, lightly beaten
- ½ cup bread crumbs

Cut a lengthwise slit in center of thickest part of each chicken breast to form a pocket. Fill each pocket with ¼ of the cheese and ham strips, secure with a wooden pick. Dip each filled breast into egg then roll in crumbs; coat evenly. Place breasts in a baking dish. Place on convection rack on turntable. Cook at COMBI HIGH for 12 to 15 minutes or until chicken is thoroughly cooked. Remove wooden picks before serving. 4 servings.

ROASTED CHICKEN WITH GARLIC AND ROOT VEGETABLES

- 2 carrots, pared, cut into 2-inch pieces
- 2 stalks celery, cut into 2-inch pieces
- 1 large sweet potato, pared, cut into 2-inch pieces
- 1 medium onion, peeled, cut into 2-inch pieces
- 1 small rutabaga, pared, cut into 2-inch pieces
- 2 tablespoons water
- 2 tablespoons butter or margarine, melted
- 5 cloves garlic, peeled, slivered
- ½ teaspoon dried rosemary leaves
- ¼ teaspoon dried thyme leaves
- 2½ to 3 pound whole chicken
- fresh thyme

Put carrots, celery, sweet potato, onion, rutabaga, and water into a 3-quart microwavable casserole. Cook covered at POWER HI for 10 minutes or until fork-tender; stir once. Set aside. Meanwhile, place garlic, rosemary, and thyme into cavity of chicken. Place chicken on microwavable roast rack in baking dish; brush with butter. Place convection rack on turntable. Cook at COMBI HIGH for 30 to 35 minutes or until chicken is no longer pink and juices run clear; brush with butter halfway through cooking. Temperature in thigh should reach 180°F and temperature in breast should reach 170°F when done. Remove chicken and place in center of microwavable and ovenproof platter; surround with vegetables. Drizzle vegetables with chicken juices, if desired. Cook at COMBI HIGH for 5 to 7 minutes or until vegetables are thoroughly heated. Garnish with fresh thyme, if desired. 4 servings.

CHICKEN POT PIE

White Sauce (see recipe)

- 1 tablespoon butter or margarine
- ½ cup thinly sliced carrots
- ½ cup thinly sliced celery
- ½ cup thinly sliced mushrooms
- ½ cup snow pea pods (about 2 inches each)
- ¼ cup diced red pepper
- 2 cups cubed, cooked chicken
- 1 refrigerated, ready-to-bake pie crust

Prepare White Sauce as directed in recipe; set aside. Put butter, carrots, celery, mushrooms, pea pods, and red pepper into a 1-quart microwavable and ovenproof casserole. Cook covered at POWER HI for 4 to 5 minutes or until vegetables are tender-crisp; stir once. Preheat CONVECTION to 400°F. Add chicken and white sauce to vegetables; stir well. Top with crust; trim and flute edge. Cut steam vent in center of crust. Cook at CONVECTION (400°F) for 15 to 20 minutes or until sauce is hot and crust is lightly browned. 4 servings.

CHICKEN ENCHILADAS

- 1 cup finely chopped green pepper
- ½ cup finely chopped zucchini
- 1 clove garlic, minced
- 1 can (10 ounces) enchilada sauce
- 1 can (8 ounces) tomato sauce
- 2 cups chopped, cooked chicken
- ½ cup refried beans
- ½ teaspoon dried oregano leaves
- ¼ teaspoon ground cumin
- ¼ teaspoon salt
- 8 (6-½ inch) flour tortillas
- 1 cup shredded Cheddar cheese

Combine green pepper, zucchini, and garlic in a 1½-quart microwavable casserole. Cook covered at POWER HI for 3 to 4 minutes or until vegetables are tender. Combine enchilada and tomato sauces; reserve ½ cup. Add remaining sauce to green pepper mixture. Stir in chicken, refried beans, oregano, cumin, and salt; mix well. Cook covered at POWER HI for 3 to 4 minutes or until thoroughly heated; stir once. Set aside. Soften tortillas by placing between damp paper towels. Cook at POWER HI for 45 to 60 seconds or until warm. Spoon ½ cup of chicken mixture into center of each tortilla; roll up. Place seam side down in a 1½ quart microwavable baking dish. Pour reserved sauce over tortillas. Cook uncovered at POWER HI for 6 to 7 minutes or until thoroughly heated. Sprinkle with Cheddar cheese. Cook uncovered at POWER HI for 1 to 2 minutes or until cheese is melted. Let stand 2 minutes. 4 servings.

CHICKEN MILANO

- 1 egg, beaten
- 1 teaspoon water
- ⅔ cup corn flake crumbs
- 2 tablespoons grated Parmesan cheese
- 2 tablespoons grated Romano cheese
- 1 teaspoon dried basil leaves
- 1 teaspoon salt
- ½ teaspoon dried oregano leaves
- 1 clove garlic, minced
- 1 tablespoon chopped fresh parsley
- ¾ teaspoon paprika
- ¼ teaspoon black pepper
- 2½ to 3 pound chicken, cut into serving pieces

Beat egg and water in a shallow bowl. For coating, combine crumbs, Parmesan and Romano cheeses, basil, salt, oregano, garlic, parsley, paprika, and pepper on a sheet of waxed paper. Dip chicken pieces into egg mixture then roll in coating mixture. Arrange chicken pieces in baking dish and place on convection rack with thickest portions toward outside of dish. Place rack on turntable. Cook at COMBI HIGH for 25 to 30 minutes or until chicken is no longer pink and juices run clear. Let stand 5 minutes. 4 servings.

Fish

FLOUNDER WITH FRESH VEGETABLES

- 1 cup thinly sliced mushrooms
- $\frac{3}{4}$ cup coarsely chopped, seeded, peeled fresh plum tomatoes (about 4 ounces)
- $\frac{1}{4}$ cup coarsely chopped green pepper
- $\frac{1}{4}$ cup coarsely chopped red pepper
- $\frac{1}{4}$ cup thinly sliced green onions
- 1 clove garlic, minced
- 3 tablespoons chopped fresh parsley
- 1 pound flounder fillets
- $\frac{1}{4}$ teaspoon salt
- $\frac{1}{8}$ teaspoon black pepper
- $\frac{1}{8}$ teaspoon dried dill weed
- $\frac{1}{8}$ teaspoon dried thyme leaves
- 1 tablespoon dry white wine
- 1 tablespoon fresh lemon juice

Combine mushrooms, tomatoes, green and red peppers, green onions, and garlic in a 1-quart glass measuring cup. Cover with plastic wrap; vent. Cook at POWER HI for 3 to 4 minutes or until vegetables are tender-crisp. Add parsley; mix well. Set aside. Arrange flounder fillets with thickest portions toward outside edge in an 8x8x2-inch glass baking dish. Sprinkle with salt, pepper, dill weed, and thyme. Spoon vegetable mixture over fish; sprinkle with wine and lemon juice. Cover with plastic wrap; vent. Cook at POWER HI for 5 to 6 minutes or until fish is opaque and flakes easily when tested with a fork. Let stand covered 2 minutes. 4 servings.

HALIBUT STEAKS WITH TOMATO-HERB SAUCE

- 1 tablespoon butter or margarine
- $\frac{1}{4}$ cup finely chopped onion
- 1 clove garlic, minced
- 2 cups chopped, seeded tomatoes
- 2 tablespoons dry white wine
- 2 tablespoons chopped fresh parsley
- 2 tablespoons chopped fresh basil leaves
- 4 small halibut steaks, (about 1 pound), cut 1-inch thick
- 2 tablespoons lemon juice
- $\frac{1}{4}$ teaspoon salt
- $\frac{1}{8}$ teaspoon black pepper

Put butter, onion, and garlic into a $\frac{1}{2}$ -quart baking dish. Cook uncovered at POWER HI for 2 to 3 minutes or until vegetables are tender-crisp. Add tomatoes, wine, parsley, and basil; stir well. Cook uncovered at POWER HI for 3 to 4 minutes or until thoroughly heated. Place halibut steaks on top of tomato-herb sauce. Sprinkle fish with lemon juice, salt, and pepper. Cover with plastic wrap; vent. Cook covered at POWER HI for 6 to 7 minutes or until fish is opaque and flakes easily with a fork. Let stand covered for 2 minutes before serving. 4 servings.

SHRIMP PRIMAVERA

- White Sauce (see recipe)
- 2 tablespoons butter or margarine
- 1 small zucchini (about 6 ounces), cut lengthwise into quarters sliced $\frac{1}{2}$ -inch thick
- 1 cup broccoli flowerets
- 1 cup quartered fresh mushrooms
- 1 cup (2-inch lengths) asparagus
- $\frac{1}{2}$ cup thinly sliced carrots
- 2 tablespoons butter
- $\frac{1}{2}$ pound medium shrimp, shelled, deveined
- 2 tablespoons chopped fresh basil leaves
- 4 ounces fettucine noodles, cooked, drained
- $\frac{1}{4}$ cup grated Parmesan cheese

Prepare thin White Sauce as directed in recipe; set aside. Put butter, zucchini, broccoli, mushrooms, asparagus, and carrots into 2-quart microwavable casserole. Cook covered at POWER HI for 5 to 6 minutes or until vegetables are tender; drain. Stir in shrimp. Cook covered at POWER HI for 1 minute. Add basil and reserved white sauce; stir to coat shrimp mixture. Cook uncovered at POWER HI for $2\frac{1}{2}$ to 3 minutes or until shrimp are opaque. Let stand 1 minute. Pour vegetable-shrimp mixture over cooked noodles; sprinkle with Parmesan cheese. Serve immediately. 4 servings.

BAKED SALMON FILLETS WITH CUCUMBER SAUCE

- $1\frac{1}{2}$ cups chopped, pared cucumber
- 2 tablespoons thinly sliced green onion
- 2 tablespoons chopped fresh mint leaves
- $\frac{1}{2}$ teaspoon salt, divided
- $\frac{1}{4}$ teaspoon white pepper, divided
- $\frac{1}{2}$ cup dairy sour cream
- $\frac{1}{4}$ cup plain yogurt
- $\frac{1}{4}$ teaspoon paprika
- 2 salmon fillets (7 to 8 ounces each), skinned
- 1 tablespoon butter or margarine
- 1 tablespoon lime juice
- fresh chives
- mint leaves

For cucumber sauce, combine cucumber, green onion, mint leaves, $\frac{1}{4}$ teaspoon salt, and $\frac{1}{8}$ teaspoon pepper in a small bowl. Let stand 15 minutes. Add sour cream, yogurt, and paprika; mix well. Cover and refrigerate. Put salmon fillets into an 8x8x2-inch glass baking dish. Dot with butter; sprinkle with lime juice and remaining salt and pepper. Place CONVECTION Rack on turntable. Place baking dish on rack. Cook uncovered at COMBI LOW for 15 to 20 minutes or until fish flakes easily when tested with fork. Garnish with fresh chives and mint leaves. Serve with sauce. May also be served chilled. 2 servings.

HALIBUT STEAKS WITH TOMATO-HERB SAUCE

- 1 tablespoon butter or margarine
- ¼ cup finely chopped onion
- 1 clove garlic, minced
- 2 cups chopped, seeded tomatoes
- 2 tablespoons dry white wine
- 2 tablespoons chopped fresh parsley
- 2 tablespoons chopped fresh basil leaves
- 4 small halibut steaks, (about 1 pound), cut 1-inch thick
- 2 tablespoons lemon juice
- ¼ teaspoon salt
- ⅛ teaspoon black pepper

Put butter, onion, and garlic into a 1½-quart baking dish. Cook uncovered at POWER HI for 2 to 3 minutes or until vegetables are tender-crisp. Add tomatoes, wine, parsley, and basil; stir well. Cook uncovered at POWER HI for 3 to 4 minutes or until thoroughly heated. Place halibut steaks on top of tomato-herb sauce. Sprinkle fish with lemon juice, salt, and pepper. Cover with plastic wrap; vent. Cook covered at POWER HI for 6 to 7 minutes or until fish is opaque and flakes easily with a fork. Let stand covered for 2 minutes before serving. 4 servings.

JAMBALAYA

- ½ pound Italian sausage
- 1 tablespoon olive oil
- ½ cup coarsely chopped celery
- ½ cup coarsely chopped green pepper
- ½ cup coarsely chopped onion
- 1 pound bone-in chicken breasts, cut into serving size pieces
- 1 can (16 ounces) whole tomatoes, drained, seeded, coarsely chopped
- 1 can (10¾ ounces) condensed chicken broth
- 1 cup uncooked long-grain white rice
- ¼ cup tomato paste
- 1 clove garlic, minced
- 1 bay leaf
- ¼ teaspoon ground red pepper
- 1 pound medium shrimp, shelled, deveined
- Sliced green onion

Pierce sausage and put on a microwavable plate. Cover with plastic wrap; vent. Cook covered at POWER HI for 4 to 5 minutes or until sausage is no longer pink. Let stand 10 minutes. Cut into 1-inch pieces; set aside. Combine olive oil, celery, green pepper, and onion in a 3-quart microwavable casserole. Cook uncovered at POWER HI for 5 minutes; stir once. Add sausage, chicken pieces, tomatoes, chicken broth, rice, tomato paste, garlic, bay leaf, and red pepper; stir well. Cook covered at POWER HI for 25 to 27 minutes or until rice is tender; stir twice. Stir in shrimp. Cook covered at POWER HI for 3 to 4 minutes or until shrimp are opaque. Discard bay leaf. Garnish with sliced green onion. 6 to 8 servings.

Beef

HOMESTYLE MEAT LOAF

- ½ cup finely chopped onion
- ¼ cup finely chopped celery
- 1 tablespoon butter
- 1 clove garlic, minced
- 1½ pounds lean ground beef
- 1 slice white bread, crust trimmed, torn into small pieces
- 1 egg, slightly beaten
- 2 teaspoons Worcestershire sauce
- ¼ teaspoon salt
- ⅛ teaspoon black pepper
- ¼ cup ketchup

Put onion, celery, butter, and garlic into a 2-cup glass measuring cup. Cook uncovered at POWER HI for 3 minutes; set aside. Put beef into a medium mixing bowl. Add cooked vegetables, bread, egg, Worcestershire sauce, salt, and pepper; mix well. Shape beef mixture into a rectangular loaf, about 6x4-inches; place in a microwavable baking dish. Spread ketchup on top. Place convection rack on turntable. Place baking dish on convection rack. Cook at COMBI HIGH for 30 to 35 minutes or until internal temperature reaches 165°F. Let stand 5 minutes.

BEEF GOULASH

- 1 to 1½ pounds boneless beef chuck top blade pot roast, cut into ¾-inch cubes
- ¼ cup flour
- 1 can (16 ounces) whole tomatoes, drained, chopped
- 2 medium potatoes, pared, cut into 8 pieces each
- 1 cup thinly sliced carrots
- ½ cup coarsely chopped onions
- ⅔ cup water
- 1 tablespoon lemon juice
- 1½ teaspoons instant beef bouillon granules
- 1½ teaspoons paprika
- ½ teaspoon garlic powder
- ¼ teaspoon dried dill weed

Put beef and flour into a large plastic food storage bag; shake to coat beef. Empty beef-flour mixture into a 3-quart microwavable casserole. Stir in tomatoes, potatoes, carrots, onions, water, lemon juice, bouillon, paprika, garlic, and dill weed. Cook covered at POWER HI for 5 minutes and then at POWER 5 for 65 to 70 minutes or until beef is tender; stir three or four times. Let stand covered 10 minutes. 4 to 6 servings.

BEEF STROGANOFF

- 2 tablespoons butter or margarine
- 1½ cups sliced fresh mushrooms (about 6 ounces)
- 1 small onion, thinly sliced, separated into rings
- 1½ pounds boneless beef round steak, trimmed
- 1 can (10¾ ounces) condensed cream of mushroom soup
- ¼ cup water
- 1 tablespoon chopped fresh parsley or ½ teaspoon dried parsley
- ½ teaspoon dry mustard
- ¼ teaspoon dried sage leaves, crushed
- ⅛ teaspoon black pepper
- ⅓ cup dairy sour cream

Put butter, mushrooms, and onion into a 2-quart microwavable casserole. Cook uncovered at POWER HI for 2½ to 3 minutes or until vegetables are tender. Slice beef diagonally across the grain into 4x¼-inch strips. Add beef strips to vegetable mixture; mix well. Cook uncovered at POWER HI 4 to 4½ minutes or until pink nearly disappears. Combine soup, water, parsley, dry mustard, sage, and pepper in a 2-cup glass measuring cup; stir into beef mixture. Cook covered at POWER HI for 5 to 6 minutes; stir once. Stir in sour cream. Let stand covered 5 minutes. 4 servings.

Pork

PORK BACK RIBS WITH BARBECUE SAUCE

- 1½ pounds pork loin back ribs
- ½ cup water
- 1 cup barbecue sauce

Cut ribs into serving size pieces. Place ribs bone side down in a large cooking bag. Place bag in an 8x8x2-inch glass baking dish; add water. Close bag loosely with microwavable closure. Cook at POWER HI for 5 minutes and then at POWER 5 for 35 to 45 minutes or until meat is fork-tender; turn ribs over halfway through cooking. Remove ribs from cooking bag; place on microwavable and ovenproof roast rack in baking dish. Brush with barbecue sauce. Place convection rack on turntable. Place baking dish on convection rack. Cook at COMBI LOW for 5 minutes. Turn ribs over; brush with barbecue sauce. Cook at COMBI LOW for 5 minutes. 2 servings.

APRICOT-STUFFED PORK CHOPS

- 4 boneless, butterflied pork loin chops, (about 2 pounds, 1-inch thick)
- ¼ cup butter or margarine, melted
- ¼ cup finely chopped dried figs
- 1 can (8-¾ ounces) apricot halves, drained and finely chopped (reserve ¼ cup syrup)
- 1 package (6 ounces) herb-seasoned stuffing mix
- ¾ cup chicken broth
- ½ teaspoon dried marjoram leaves
- ¼ teaspoon black pepper

Make two pockets in each pork chop, cutting from outside edge almost to center. For stuffing, combine butter, figs, apricots, stuffing mix, chicken broth, reserved syrup, marjoram, and pepper in a mixing bowl; mix well. Fill pockets with stuffing mixture. Arrange chops on microwavable and ovenproof roast rack in a baking dish with thickest portions towards outside. Place convection rack on turntable. Place baking dish on convection rack. Cook at COMBI LOW for 35 to 40 minutes or until internal temperature reaches 160°F and juices run clear. Cut chops in half through uncut center portion to serve. 8 servings.

PORK ROAST WITH HERBS

- 3 cloves garlic, minced, divided
- 1½ teaspoons dried rosemary leaves, divided
- 1 teaspoon grated fresh lemon peel
- ¼ teaspoon crushed dried sage leaves
- ¼ teaspoon black pepper, divided
- 3 pound rolled pork loin roast, boneless
- 2 tablespoons fresh lemon juice
- ⅓ cup unseasoned dry bread crumbs
- 1 tablespoon chopped fresh parsley
- ½ teaspoon dried thyme leaves
- ½ teaspoon dried oregano leaves
- lemon and carrot slices
- fresh herbs

Combine 2 cloves garlic, 1 teaspoon rosemary, lemon peel, sage, and ⅛ teaspoon black pepper in a small bowl. Untie roast and rub inside surface with herb mixture. Roll and tie roast with string. Brush lemon juice on outside of surface. Combine bread crumbs, parsley, thyme, oregano, and remaining garlic, rosemary, and pepper on a sheet of waxed paper. Roll roast in crumb mixture; press onto roast. Place roast fat side down in a microwavable baking dish on convection rack. Cook at COMBI LOW for 60 to 65 minutes or until meat thermometer inserted in center of meat registers 160°F; turn over halfway through cooking. Let stand tented with foil 10 minutes before slicing. Garnish with lemon and carrot slices and fresh herbs. 12 servings.

Vegetables and Side Orders

LEMON CREAMED SPINACH

White Sauce (see recipe)

- 1 package (10 ounces) frozen chopped spinach
- 1 teaspoon freshly grated lemon peel
- ¼ teaspoon salt

Prepare White Sauce as directed in recipe; set aside. Remove outer wrapping from spinach package. Place package on double thickness of paper towels on turntable. Cook at POWER HI for 5 to 6 minutes or until spinach is cooked. Let stand 2 minutes. Drain spinach thoroughly. Combine spinach, lemon peel, reserved white sauce, and salt in a 1-quart microwavable casserole. Cook uncovered at POWER 7 for 4 to 5 minutes or until thoroughly heated. Let stand 2 minutes. 4 servings.

BROCCOLI WITH HOLLANDAISE SAUCE

- 1½ pounds broccoli, cut into 4-inch spears
- 1 tablespoon water
- 3 egg yolks
- 1 tablespoon fresh lemon juice
- ⅛ teaspoon white pepper
- ½ cup butter or margarine
- pimento strips
- lemon wedges

Arrange broccoli spears in a 1½-quart microwavable baking dish with flowerets towards center of dish; add water. Cover with plastic wrap; vent. Cook covered at POWER HI for 8 to 10 minutes or until broccoli is tender; drain. Cover to keep warm; set aside. Blend egg yolks, lemon juice, and pepper with a wire whisk in a 1-quart microwavable casserole; set aside. Put butter into a 2-cup glass measuring cup. Cook uncovered at POWER HI for 1 to 1½ minutes or until butter is melted. Gradually pour butter into egg mixture stirring constantly with whisk. Cook uncovered at POWER 5 for 1 to 1½ minutes or until thickened; stir three times with whisk. Serve over reserved broccoli. Garnish with pimento strips and lemon wedges. 4 servings.

HOT AND SAVORY POTATO SALAD

- 4 medium baking potatoes (about 2 pounds), scrubbed
- 2 tablespoons vegetable oil
- 4 slices bacon, diced
- ½ cup coarsely chopped onion
- ½ cup coarsely chopped celery
- ¼ cup cider vinegar
- 1 tablespoon sugar
- 1 tablespoon Dijon-style mustard
- ½ teaspoon salt
- ⅛ teaspoon ground red pepper
- 1 tablespoon chopped fresh parsley

Pierce potatoes several times with a fork. Place on double thickness of paper towel on turntable. Cook at POWER HI for 10 to 12 minutes or until soft to the touch; turn over halfway through cooking. Allow to cool for 1 hour. Peel potatoes; cut into ½-inch thick slices; set aside. Combine oil, bacon, onion, and celery in a 2-quart microwavable casserole. Cook uncovered at POWER HI for 5 to 6 minutes or until vegetables are tender-crisp; stir once. Add potatoes, vinegar, sugar, mustard, salt, and red pepper; stir gently to coat. Cook covered at POWER HI for 2 to 3 minutes or until thoroughly heated; stir once. Let stand for 1 minute. Add chopped parsley; stir gently. Serve immediately. 4 servings.

FRESH VEGETABLE KABOBS

- ½ cup butter or margarine
- 1 tablespoon lemon juice
- 1 teaspoon seasoned salt
- ½ teaspoon dried dill weed (or ½ teaspoon fresh chopped)
- 1 small bunch broccoli (about 1 pound), cut into 2-inch spears
- 1 medium zucchini (about ½ pound), cut into 1-inch wedges
- 1 large red pepper, cut into 1½-inch squares
- 3 small onions, cut into quarters
- 12 medium fresh mushrooms
- 1 small cauliflower (about 2 pounds), cut into 2-inch pieces

Put butter into a 2-cup glass measuring cup. Cook uncovered at POWER HI for 1 to 1¼ minutes or until butter is melted. Stir in lemon juice, seasoned salt, and dill weed. To assemble kabobs, alternate broccoli, zucchini, red pepper, onion, mushroom, and cauliflower on twelve 8-inch wooden skewers. Arrange kabobs on a 10-inch round microwavable plate; brush with butter sauce. Cover with plastic wrap; vent. Cook covered at POWER HI for 4 to 5 minutes or until vegetables are tender. Let stand covered 1 to 2 minutes. Repeat with remaining kabobs. Remove cover and brush with additional butter sauce before serving. 6 servings.

HERB ROASTED POTATOES

- 1 pound new potatoes, scrubbed
- ¼ cup vegetable oil
- 1 tablespoon chopped fresh parsley
- ½ teaspoon paprika
- ½ teaspoon salt
- ¼ teaspoon coarsely ground black pepper
- ¼ teaspoon dried rosemary leaves
- ⅛ teaspoon dried thyme leaves

Cut potatoes into quarters. Combine potatoes, oil, parsley, paprika, salt, pepper, rosemary, and thyme in a medium mixing bowl; toss lightly to coat. Turn potato mixture into an 8x8x2-inch glass baking dish. Place on convection rack. Cook uncovered at COMBI HIGH for 18 to 23 minutes or until potatoes are tender and lightly browned; stir twice. Let stand 3 to 4 minutes before serving. 4 servings.

ORANGE-MAPLE ACORN SQUASH

- ¼ cup maple syrup
- ¼ cup orange juice
- 2 tablespoons packed brown sugar
- 2 tablespoons honey
- 1 tablespoon butter or margarine
- 1 tablespoon lemon juice
- 1 teaspoon grated fresh orange peel
- ¼ teaspoon grated fresh lemon peel
- ⅛ teaspoon cinnamon
- 2 medium acorn squash (about 3 pounds)

For glaze, combine maple syrup, orange juice, brown sugar, honey, butter, lemon juice, orange peel, lemon peel, and cinnamon in a 2-cup glass measuring cup. Cook uncovered at POWER HI for 6 to 7 minutes; set aside. Wash and place squash on double thickness of paper towel on turntable. Cook at POWER HI for 5 minutes. Carefully cut each squash into quarters; remove seeds and fibers. Arrange quarters on a 10-inch glass pie plate; spoon glaze into squash quarters. Cover with plastic wrap; vent. Cook at POWER HI for 14 to 15 minutes or until squash is tender. Baste with glaze halfway through cooking. Let stand 5 minutes. 8 servings.

TWICE BAKED POTATOES

- 4 medium baking potatoes (about 2 pounds), scrubbed
- 2 slices bacon
- ½ cup shredded Cheddar cheese
- ½ cup dairy sour cream
- ¼ cup half-and-half or milk
- 1 egg, beaten
- 2 tablespoons butter or margarine
- 2 tablespoons chopped fresh parsley
- 1 tablespoon thinly sliced green onions
- ¼ teaspoon salt
- ⅛ teaspoon white pepper

Pierce potatoes several times with a fork. Place on double thickness of paper towel on turntable. Cook at POWER HI for 11 to 13 minutes or until potatoes are tender; turn over halfway through cooking. Set aside. Place bacon on microwavable roast rack; cover with paper towel. Cook at POWER HI for 1½ to 2½ minutes or until just crisp. Cool and crumble; set aside. Cut a thin slice about ¼-inch from top of each potato. Scoop out centers to within ¼-inch of edge. Reserve shells. Preheat CONVECTION to 375°F. Combine potato pulp, crumbled bacon, Cheddar cheese, sour cream, half-and-half, egg, butter, parsley, green onion, salt, and pepper in a large mixing bowl. Beat at medium speed of electric mixer until blended. Spoon ¼ of the potato mixture into each shell. Arrange potatoes in a 1½-quart baking dish. Cook at CONVECTION (375°F) for 25 to 30 minutes or until lightly browned and thoroughly heated. 4 servings.

BACON SCALLOPED POTATOES

- 2 slices bacon
- 2 large baking potatoes (about 1¾ pounds), peeled and thinly sliced
- ½ teaspoon salt
- ¼ teaspoon white pepper
- 1 cup half-and-half or milk
- 1 cup shredded Cheddar cheese
- 1 tablespoon butter or margarine

Place bacon on double thickness of paper towel. Place on CONVECTION Rack and cover with more paper towel. Cook at POWER HI for 1½ to 2½ minutes or until just crisp. Cool; crumble. Layer potatoes and bacon in an 8x8x2-inch glass baking dish; sprinkle with salt and pepper. Pour half-and-half over potatoes. Sprinkle Cheddar cheese over potatoes; dot with butter. Cook uncovered at COMBI HIGH for 20 to 25 minutes or until potatoes are tender. 4 servings.

WHITE SAUCE

- 1 tablespoon butter or margarine
- 1 tablespoon flour
- ¼ teaspoon salt
- ⅛ teaspoon pepper
- 1 cup half-and-half or milk

Put butter into a 2-cup glass measuring cup. Cook uncovered at POWER HI for 30 to 60 seconds or until butter is melted. Stir in flour, salt, and pepper making a smooth paste. Gradually add milk; stir well. Cook uncovered at POWER HI for 2 to 3 minutes or until thickened; stir vigorously two or three times. Let stand 1 minute. Serve as a light sauce for entrées or open-faced sandwiches. 1 cup thin white sauce.

VARIATIONS

Medium White Sauce: Increase butter and flour to 2 tablespoons. Continue as directed. Serve with cooked vegetables for a creamed side dish.

Thick White Sauce: Increase butter and flour to 3 tablespoons. Continue as directed. Serve as topping for entrées of chicken or turkey or in casseroles.

COUNTRY BUTTERMILK BISCUITS

- 2 cups flour
- 1 tablespoon baking powder
- 1 tablespoon sugar
- ½ teaspoon baking soda
- ½ teaspoon salt
- ½ cup butter or margarine, cut into small pieces
- ⅔ cup buttermilk

Preheat CONVECTION to 450°F. Combine flour, baking powder, sugar, baking soda, and salt in a medium mixing bowl. Cut butter into flour until mixture resembles coarse crumbs; add buttermilk. Mix just until dry ingredients are moistened; do not over mix. Turn dough out onto a lightly floured surface; knead 8 to 10 times. Roll or pat out ½-inch thick. Cut with 2-inch cutter dipped in flour. Place cut biscuits on ungreased 12-inch metal pizza pan. Place on CONVECTION Rack. Cook CONVECTION (450°F) for 10 to 12 minutes or until lightly browned. Serve warm. 20 biscuits.

TOASTED GARLIC BREAD

- ½ cup butter or margarine, softened
- 3 tablespoons chopped fresh parsley
- 2 cloves garlic, minced
- ¼ teaspoon salt
- ¼ teaspoon black pepper
- 1 loaf (10-inch) round Italian bread
- 2 tablespoons grated Parmesan cheese

Preheat CONVECTION to 450°F. Combine butter, parsley, garlic, salt, and pepper in a small mixing bowl; mix well. Cut bread loaf in half lengthwise; spread seasoned butter on each half. Sprinkle with Parmesan cheese. Place CONVECTION Rack on turntable. Place one bread half on rack. Cook at CONVECTION (450°F) for 5 to 7 minutes or until lightly browned. Repeat with remaining bread half. 8 servings.

Desserts

CARAMEL CUSTARD

- 1 cup sugar, divided
- 3 tablespoons water
- 2 cups milk
- 4 eggs, beaten
- ½ teaspoon vanilla extract

Combine ⅔ cup sugar and water in a 1-cup glass measuring cup. Cook uncovered at POWER HI for 5½ to 6 minutes or until sugar is golden brown. Pour into six buttered 6-ounce glass custard cups; set aside. Pour milk into a 2-cup glass measuring cup. Cook uncovered at POWER HI for 4 minutes. Beat eggs, remaining sugar, and vanilla in a 1-quart glass measuring cup; gradually stir in milk. Pour over caramel in custard cups. Arrange in a circular pattern on turntable. Cook uncovered at POWER 5 for 9 to 10 minutes or until custard is set. Let stand until cool. Refrigerate covered for at least 3 hours before inverting to serve. 6 servings.

GRAHAM CRACKER CRUST

- ¼ cup butter or margarine
- 1¼ cups graham cracker crumbs
- 2 tablespoons sugar
- ¼ teaspoon cinnamon

Put butter in a 9-inch glass pie plate. Cook uncovered at POWER HI for 1 to 1¼ minutes or until butter is melted. Mix crumbs, sugar, and cinnamon; add to butter. Mix well. Press mixture firmly against bottom and sides of pie plate. Cook uncovered at POWER HI for 1½ to 2 minutes or until set. Cool completely before filling. One 9-inch crust.

CINNAMON CRESCENTS

- ¼ cup raisins
- 3 tablespoons coarsely chopped pecans
- 2 tablespoons sugar
- 2 tablespoons cinnamon
- 1 package (8 ounces) refrigerated crescent dinner rolls
- 2 tablespoons butter or margarine, melted

Preheat CONVECTION to 400°F. Combine raisins, pecans, sugar, and cinnamon; reserve 1 tablespoon of mixture. Unroll and separate dough into eight triangles. Brush top surface of dough triangles with 1 tablespoon melted butter; sprinkle evenly with raisin mixture. Roll up according to package directions. Brush tops with remaining butter; sprinkle with reserved raisin mixture. Place rolls on ungreased 12-inch metal pizza pan. Place on CONVECTION Rack. Cook at CONVECTION (400°F) for 12 to 14 minutes or until lightly browned. Serve warm. 8 rolls.

PIE CRUST

- 1 cup flour
- ¼ teaspoon salt
- 6 tablespoons vegetable shortening
- 3 to 4 tablespoons water

Combine flour and salt in a mixing bowl. Cut shortening into flour to form coarse crumbs. Sprinkle with water 1 tablespoon at a time; mix with a fork until particles are moistened and cling together. Form dough into a ball. Preheat CONVECTION to 450°F. Place dough on a lightly floured surface. Roll out 1/8-inch thick (about a 12-inch circle) and place in a 9-inch glass pie plate. Trim and flute edge. Prick sides and bottom of crust with a fork. Cook at CONVECTION (450°F) for 10 to 12 minutes or until dry and opaque. One 9-inch crust.

CREAM CHEESE AND RICOTTA FRUIT PIE

- Graham Cracker Crust (see recipe)
- 2 packages (3 ounces each) cream cheese
- ⅔ cup ricotta cheese
- 5 tablespoons sugar, divided
- 2 eggs
- 1 tablespoon fresh lemon juice
- ⅛ cup sour cream
- 1 cup sliced fresh strawberries, peaches, or grapes

Prepare Graham Cracker Crust as directed in recipe; set aside. Put cream cheese into a 2-quart microwavable casserole. Cook uncovered at POWER 5 for 1 to 1½ minutes or until softened. Add ricotta cheese, 4 tablespoons sugar, eggs, and lemon juice. Beat at medium speed with electric mixer until smooth. Pour into prepared graham cracker crust. Cook uncovered at POWER 5 for 11 to 13 minutes or until edges of filling are firm and center is almost set. Let stand on counter for 10 minutes. Combine sour cream and remaining 1 tablespoon sugar in a small mixing bowl. Spread on top of pie. Refrigerate at least 2 hours. Top with fresh fruit before serving. One 9-inch pie.

APPLE-PEAR CRISP

- 6 cups pared, thinly sliced apples (about 6 medium)
- 2 cups pared, thinly sliced pears (about 2 medium)
- 2 tablespoons sugar
- 1 tablespoon fresh lime juice
- ½ teaspoon grated fresh lime peel
- ½ teaspoon ground ginger, divided
- ⅛ teaspoon ground allspice
- ½ cup flour
- ⅓ cup packed brown sugar
- ⅓ cup chopped almonds
- ¼ cup quick oats, uncooked
- ⅛ teaspoon salt
- 5 tablespoons butter or margarine, cut into small pieces

Combine apples, pears, sugar, lime juice, lime peel, ¼ teaspoon ginger, and allspice in an 8x8x2-inch glass baking dish; mix well. Combine flour, brown sugar, almonds, oats, remaining ginger, salt, and butter in a small mixing bowl. Cut butter into flour mixture with a pastry blender to form coarse crumbs. Sprinkle crumb mixture evenly over fruit. Cook at COMBI HIGH for 18 to 20 minutes or until fruit is tender and topping is crisp. Let stand 5 minutes. 8 servings.

APPLESAUCE CAKE

- 2 cups flour
- 1 teaspoon baking soda
- 1 teaspoon cinnamon
- ½ teaspoon ground nutmeg
- ¼ teaspoon ground cloves
- ¼ teaspoon salt
- ½ cup butter or margarine, softened
- 1 cup sugar
- 2 eggs
- ¾ cup applesauce
- ½ cup raisins
- ½ cup coarsely chopped walnuts

Preheat CONVECTION to 375°F. Sift together flour, baking soda, cinnamon, nutmeg, cloves, and salt; set aside. In a medium mixing bowl cream butter and sugar with electric mixer at medium speed until light. Add eggs, one at a time; beat well after each addition for a total of 2 minutes. Stir in flour mixture alternately with applesauce; mix until blended after each addition. Fold in raisins and walnuts. Pour mixture into a greased 10-cup fluted tube pan. Cook at CONVECTION (375°F) for 40 to 45 minutes or until wooden pick inserted near center comes out clean. Cool 15 minutes; remove from pan. 1 tube cake.

Quick Reference Instructions

Clock

1. Press *CLOCK* pad.
2. Press numbered pad for correct time of day.
3. Press *CLOCK* pad.

Micro Time Entry Cooking

1. Press *MICRO TIME ENTRY* pad.
2. Press numbered pads for desired cooking time.
3. Press *COOKMATIC LEVEL* pad.
4. Press numbered pads for desired cooking power.
5. Press *START* pad.

Preheat for Convection Cooking

1. Press *CONVECTION* pad twice.
2. Press numbered pad with desired oven temperature.
3. Press *START* pad.
4. When preheat is complete, "PRE-H" and "CONV" flash and signal sounds. Oven holds preheat temperature for 30 minutes or until oven door is opened.

Convection Cooking

1. Press *CONVECTION* pad.
2. Press number pad with desired oven temperature.
3. Press numbers for desired cooking time.
4. Press *START* pad.

Combination Cooking

1. Press *COMBINATION HIGH* or *COMBINATION LOW* pad.
2. Press numbered pads for desired cooking time.
3. Press *START* pad.

2-Stage Cooking Program

1. Press pad to select first cooking method.
2. Press numbered pads to enter first cooking time.
3. Press pad to select second cooking method.
4. Press numbered pads to enter time for second cooking time.
5. Press *START*.

Auto Weight Combination Cooking

1. Press *AUTO WEIGHT COMBINATION COOK* pad.
2. Press numbered pad (1-7) to select food type.
3. Press numbers for desired cooking weight.
4. Press *START* pad.

Auto Accu-Thaw

1. Press *AUTO ACCU-THAW* pad.
2. Press numbered pad (1, 2, or 3) to select food type.
3. Press numbers for desired cooking weight.
4. Press *START* pad.

Reheat Pad Cooking

1. Press *REHEAT* pad.
2. Press numbered pad (1, 2, or 3) to select food or beverage type.
3. Press numbered pad 1 or 2 to select serving size.

Cook Pad Cooking

1. Press *COOK* pad.
2. Press numbered pad (1, 2, 3, 4) to select food type.
3. Press numbered pad 1-4 to select serving size.

Popcorn Cooking

1. Place convection rack on turntable. Place popcorn package on top of convection rack.
2. Press *POPCORN* pad once for 1.8 oz. or twice for 3.5 oz. package.

Pausing Operation or Canceling Program

- Press *STOP/RESET* pad or open door to pause operation. Press *START* pad to resume defrosting.
- Press open oven door and press *STOP/RESET* pad or press *STOP/RESET* pad twice to cancel program.





